

# BALCONY & TERRACE SYSTEMS



Renoplast



# ADHESIVE BONDED CERAMIC TILE FLOORING









## RENOPLAST DRIP EDGE PROFILES

HAVE A LOOK  
ON HOW OUR  
PROFILES ARE MADE



Renoplast is a purely Polish technological enterprise built on Polish know-how and technological thought. Driven by many years of experience and growing market demand, it has developed into a manufacturer of terrace and balcony systems for various engineering technologies and applications, which are perfectly suitable for our weather conditions.

The key element of all the systems is an aluminium edging and finishing profile with a drip edge that efficiently drives water away from the balcony or terrace. Cutting edge technology and the use of solely highest quality components resulted in products that meet even the most demanding customers' needs full anti-corrosion protection combined with attractive appearance and with all elements designed to build complete and integrated systems, whose assembly is intuitive and quick.

We have placed a high value on quality, ever since Renoplast was founded. Our unrelenting focus on quality and an innovative approach to challenges related to balconies and terraces ensure continuous development of the company and constant extension of our product range. The European Technical Assessment and a modern Qualicoat-certified paint shop support, verify and validate the direction we took many years ago. Therefore, everyone, who decides to choose the solutions proposed by Renoplast, can be sure to receive professional advice and, most importantly, a product which meets the stringent requirements for building products and fully complies with the construction law in Poland.



# PROBLEMS

**CORROSION OF DRIP  
EDGE PROFILES**



**NOT WATERTIGHT DRIP  
EDGE AREA**



**INCOMPLETENESS**



**INEFFICIENT  
WATER RUN-OFF**





# SOLUTION

## ANTI-CORROSION

All Renoplast profiles are coated compliant with the highest world standards which is Qualicoat-certified.

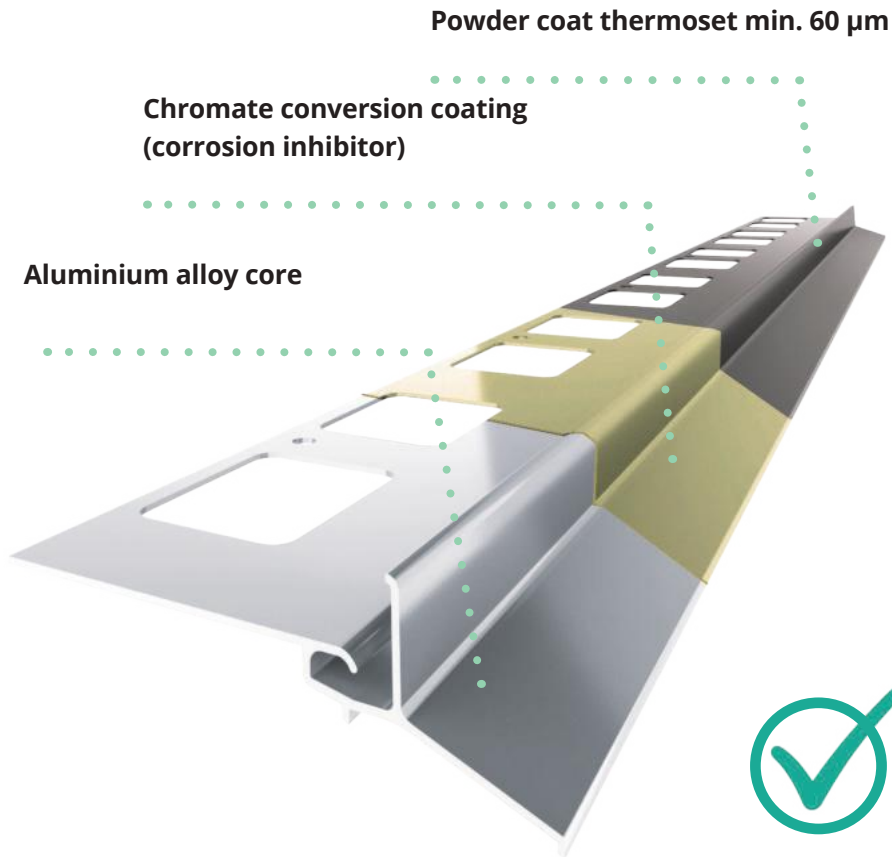

## WATERTIGHT



Innovative shape of the Renoplast profiles ensures that the connection of flooring with drip edge profile is fully watertight.



## COMPLETE SYSTEM

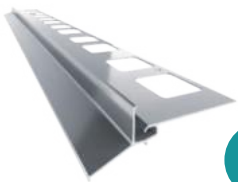
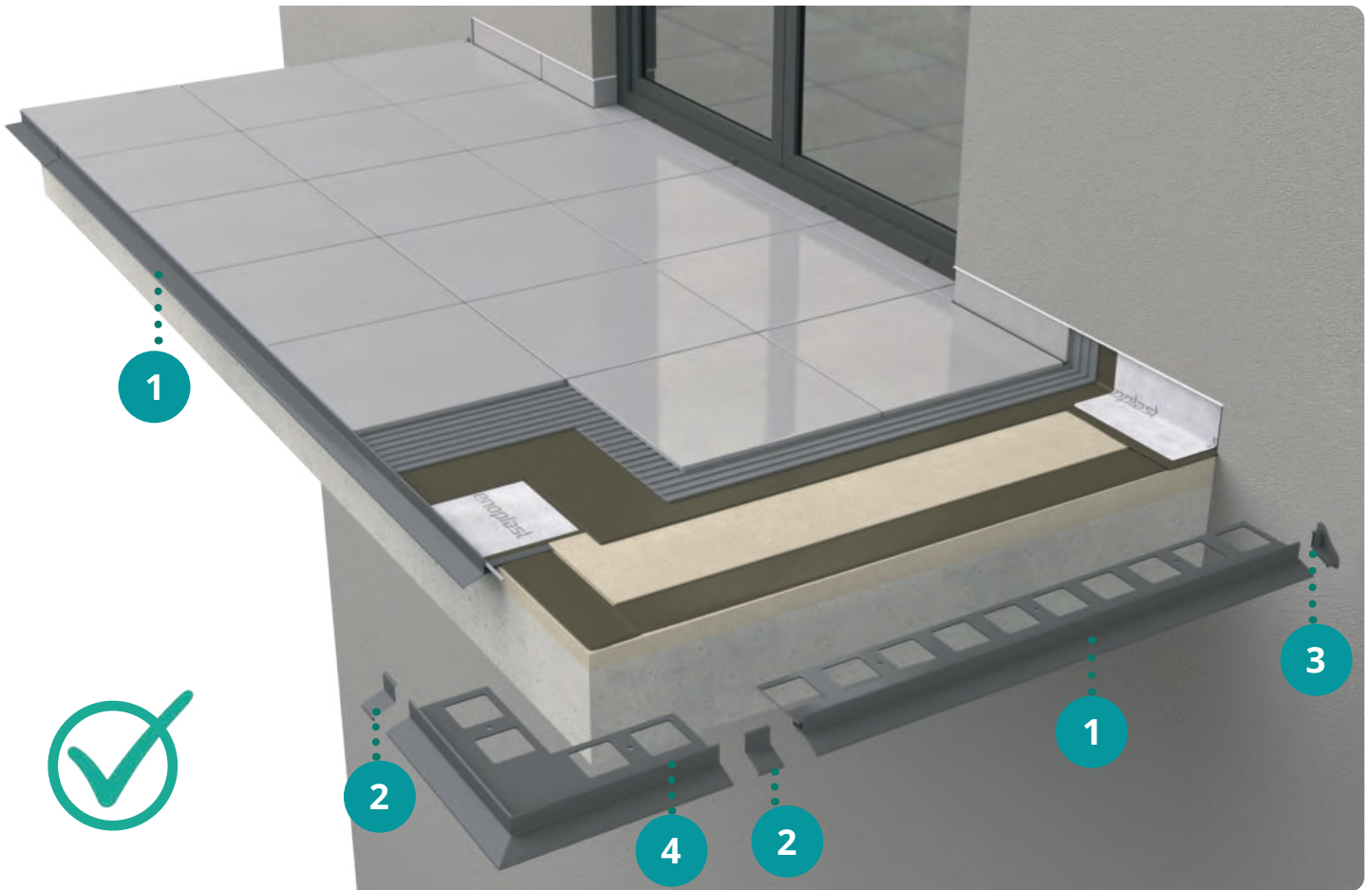

1

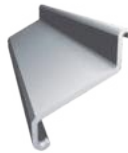

2



3



4

We offer straight profiles (1), connectors (2), end stops (3) and outside and inside corners (4) - of standard 90° and 135° angles. Customised angle corners and curved balcony profiles are also made to order.

## EFFICIENT WATER DRAINAGE

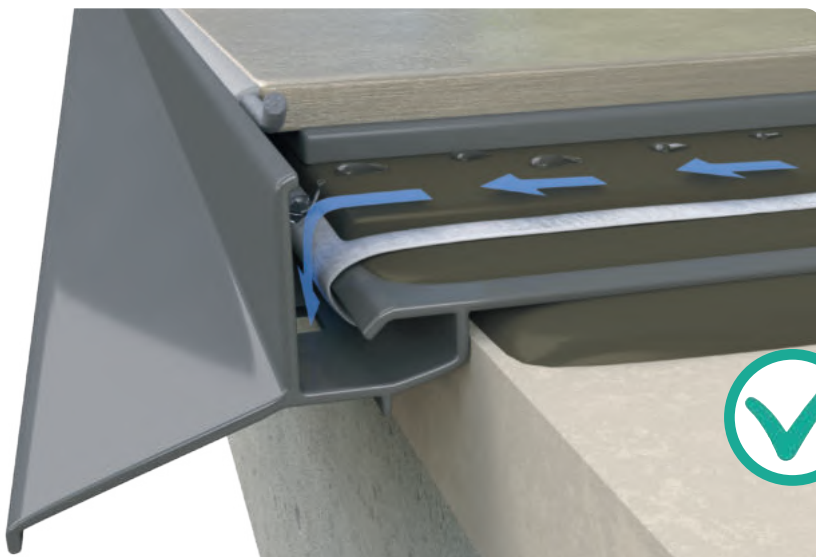

A unique feature of the Renoplast profiles are drainage holes to allow a discharge of water from the surface under the tiled balcony flooring. When the profiles are installed, the drain holes are positioned beneath to ensure that moisture is drawn away efficiently from under tiles.



# OPTIMAL K102 DRIP EDGE PROFILE

RAL 7037 RAL 7024 RAL 8019



NZ 102/90  
Outside corner 90°/135°

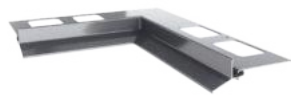

NW 102/90  
Inside corner 90°/135°

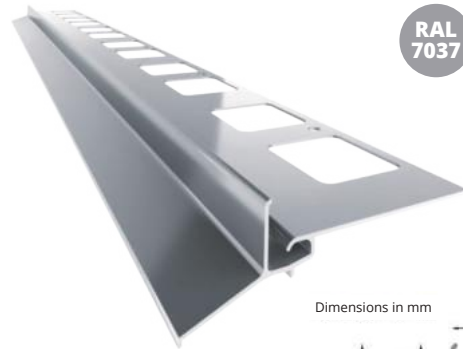

K102 OPTIMAL  
Drip edge profile

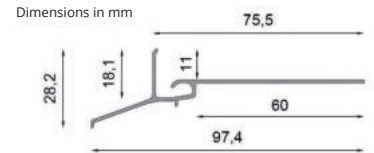

L102  
Connector



OP102  
End stop  
left/right  
(set)



CLEVER 12 cm wide  
Sealing tape

## OPTIMAL K102 PROFILE - FOR ADHESIVE TILES WITH DEDICATED CLEVER WATERPROOFING STRIP TO SEAL JOINTS WITH WATERPROOFING

- High quality at affordable price
- Watertight seal around balcony/terrace drip edges
- Guides water away from surfaces under flooring
- Designed with a slot to accommodate the CLEVER reinforcement waterproofing strip.



**INSTRUCTIONAL  
VIDEO  
K102**

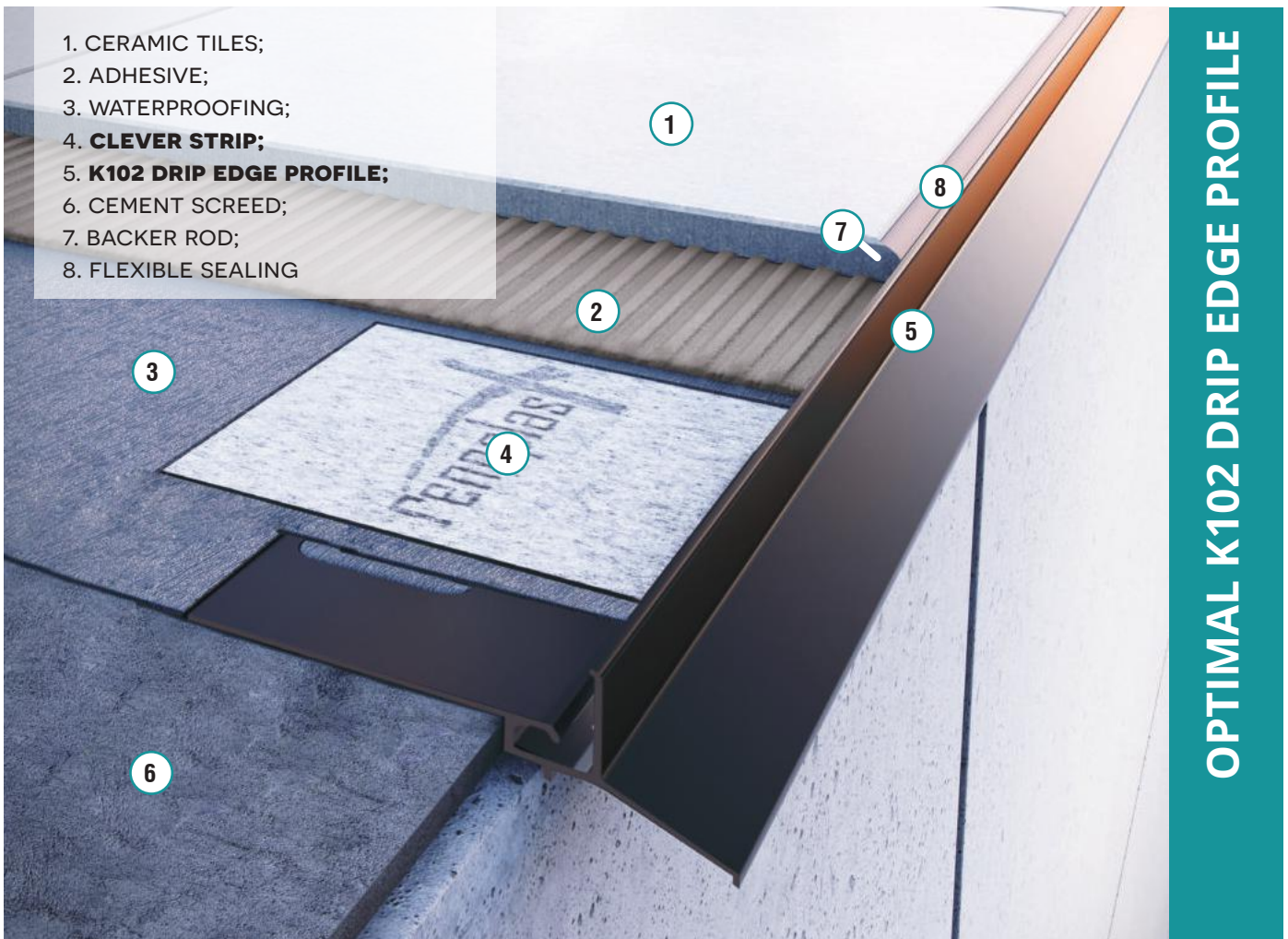

**OPTIMAL K102 DRIP EDGE PROFILE**

# BASIC K30 DRIP EDGE PROFILE

RAL 7037 RAL 7024 RAL 8019

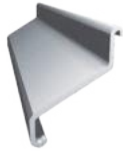
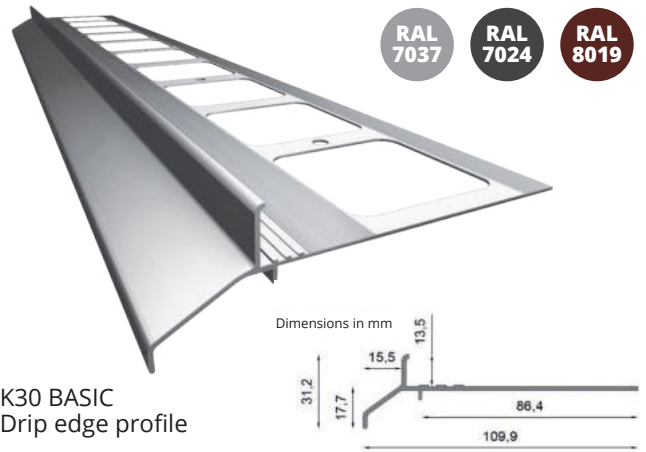

**BASIC K30 PROFILE - EDGING AND FINISHING PROFILE DESIGNED TO PROTECT THE EDGES OF TILES AND FEATURING DRAINAGE HOLES TO ALLOW MOISTURE AND WATER TO ESCAPE**

Watertight seal around balcony/terrace drip edges

- Long leg to ensure a firm support and stable embedding
- Channel moisture away from under the tile.

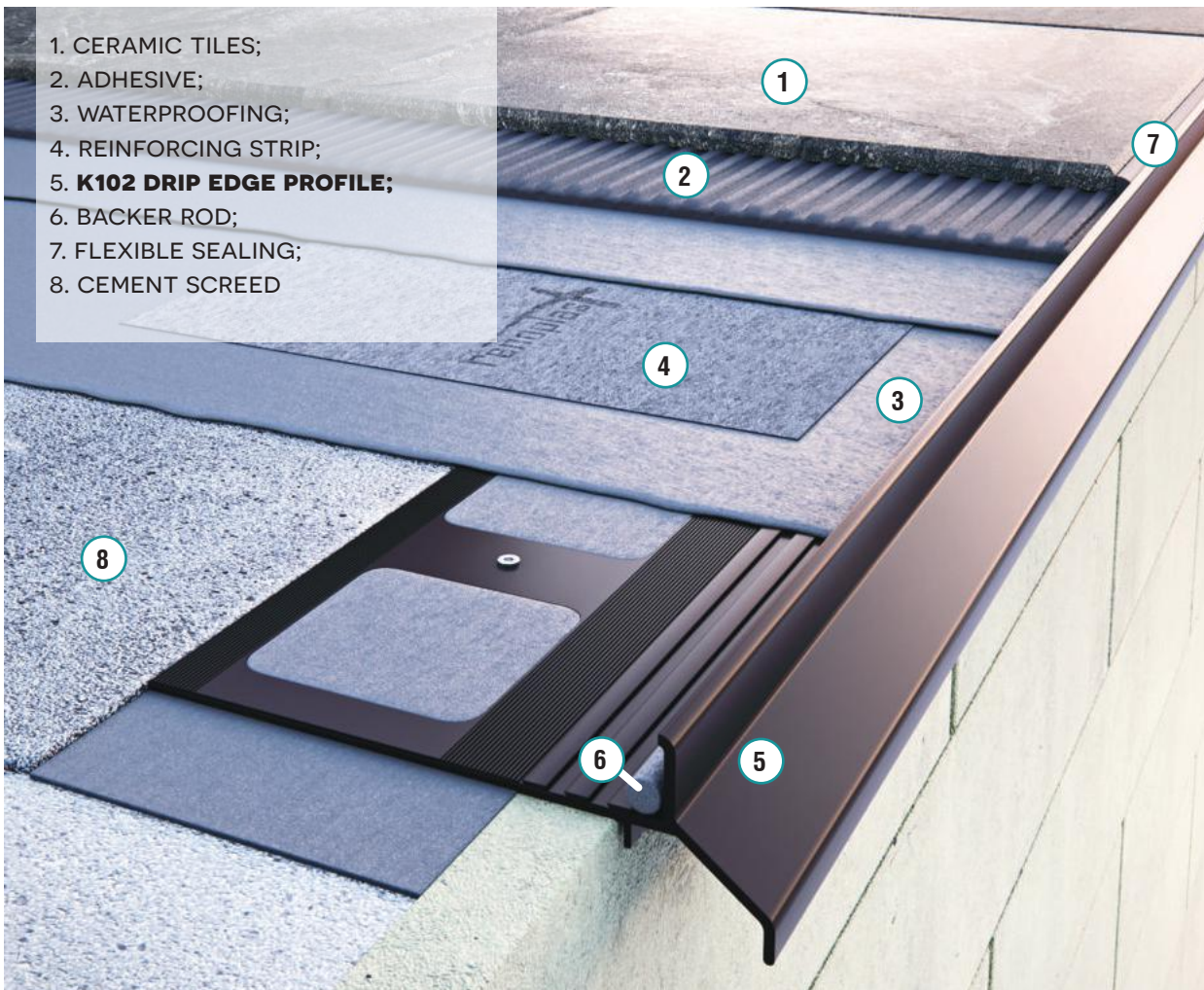

**BASIC K30 DRIP EDGE PROFILE**



# BASIC+ K40 DRIP EDGE PROFILE



NZ 40/90  
Outside corner  
90°/135°

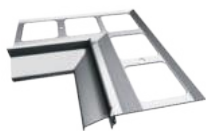

NW 40/90  
Inside corner  
90°/135°



OP40  
End stop  
left/right (set)

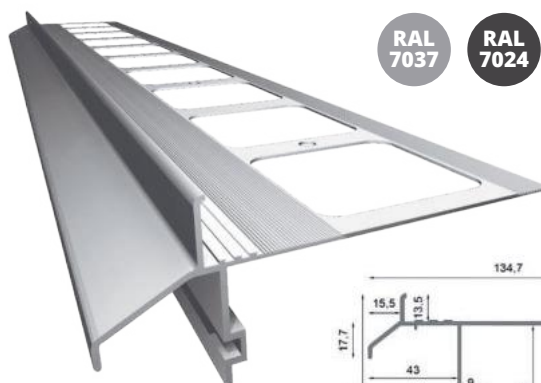

K40 BASIC+  
Drip edge profile

RAL  
7037

RAL  
7024

RAL  
8019

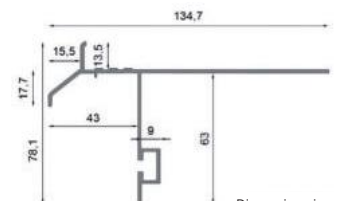

Dimensions in mm



L40  
Connector



MG75  
Gutter bracket



G75  
Gutter bracket

**BASIC+ K40 PROFILE - EDGING AND FINISHING PROFILE**  
DESIGNED TO PROTECT THE EDGES OF TILES AND FEATURING DRAINAGE HOLES TO ALLOW MOISTURE AND WATER TO ESCAPE, READY FOR THE INSTALLATION OF 75 MM PVC GUTTERS

- Watertight seal around balcony/terrace drip edges
- Long anchoring leg to ensure support and stable anchor
- Guides water away from surfaces under flooring
- Integrated fascia to allow the installation of 75 mm PVC gutters using fascia brackets MG75/G75.



**INSTRUCTIONAL  
VIDEO  
K40**

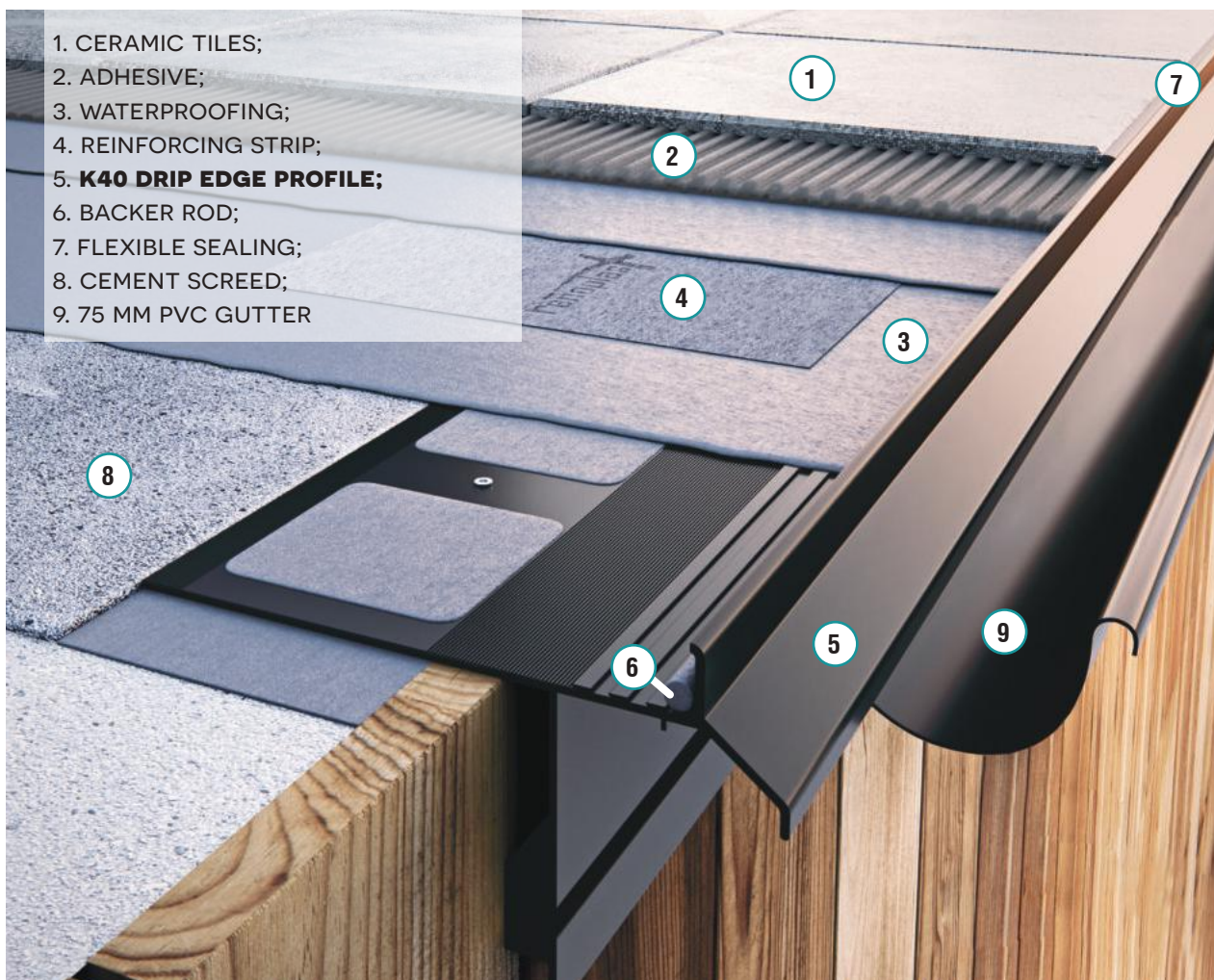

1. CERAMIC TILES;
2. ADHESIVE;
3. WATERPROOFING;
4. REINFORCING STRIP;
5. **K40 DRIP EDGE PROFILE**;
6. BACKER ROD;
7. FLEXIBLE SEALING;
8. CEMENT SCREED;
9. 75 MM PVC GUTTER

**BASIC+ K40 DRIP EDGE PROFILE**



# CLASSIC K301 DRIP EDGE PROFILE



NZ 301/90  
Outside corner 90°/135°



NW 301/90  
Inside corner 90°/135°



L301  
Connector



OP301  
End stop  
left/right (set)

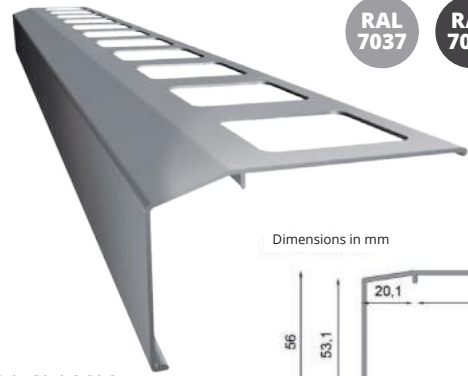

K301 CLASSIC  
Drip edge profile



Dimensions in mm

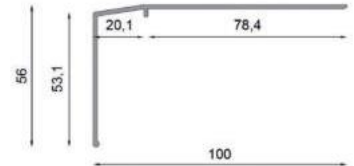

## CLASSIC K301 PROFILE - PROFILE WITH EXTENDED DRIP EDGE LIP

- Gives a robust look to your terrace or balcony
- Facilitates efficient water run-off away from the terrace or balcony.



**INSTRUCTIONAL  
VIDEO  
K301**

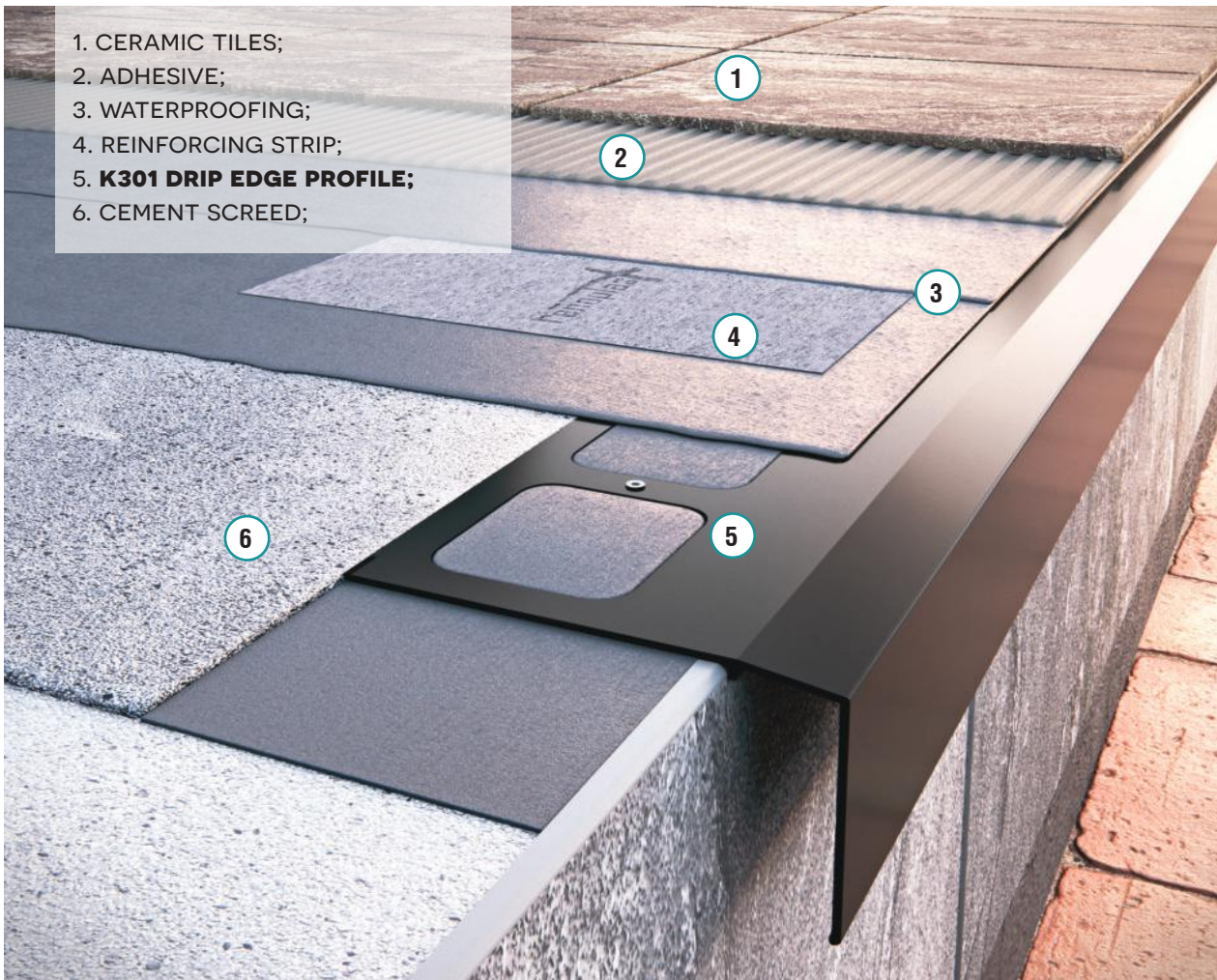

1. CERAMIC TILES;
2. ADHESIVE;
3. WATERPROOFING;
4. REINFORCING STRIP;
5. **K301 DRIP EDGE PROFILE;**
6. CEMENT SCREED;

**CLASSIC K301 DRIP EDGE PROFILE**



# PRO K35 DRIP EDGE PROFILE

RAL 7037 RAL 7024 RAL 8019



NZ 35/90  
Outside corner  
90°/135°

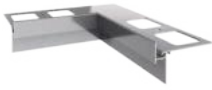

NW 35/90  
Inside corner  
90°/135°



OP35  
End stop  
left/right (set)

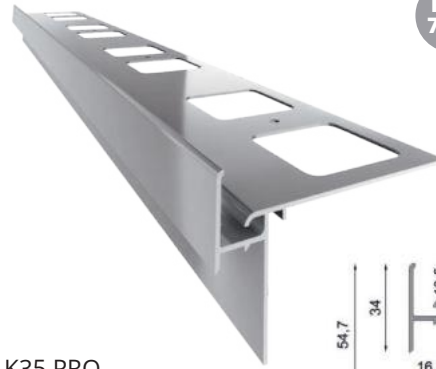

K35 PRO  
Drip edge profile

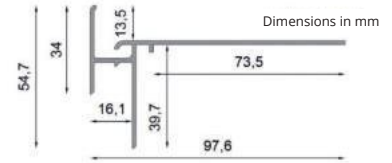

L35  
Connector



K35B



Corner connecting  
with side profile



K35  
Notch profile



R50  
Aluminium gutter



16 cm wide CLEVER  
Waterproofing strip

## PRO K35 PROFILE - EDGE PROFILE FOR EMBEDDING IN WATERPROOFING USING THE WATERPROOFING STRIP READY FOR ALUMINIUM GUTTER R50 INSTALLATION

Watertight seal around balcony/terrace drip edges

- Guides water away from surfaces under flooring
- Designed to allow the installation of the R50 gutters.



**INSTRUCTIONAL VIDEO**  
**K35**

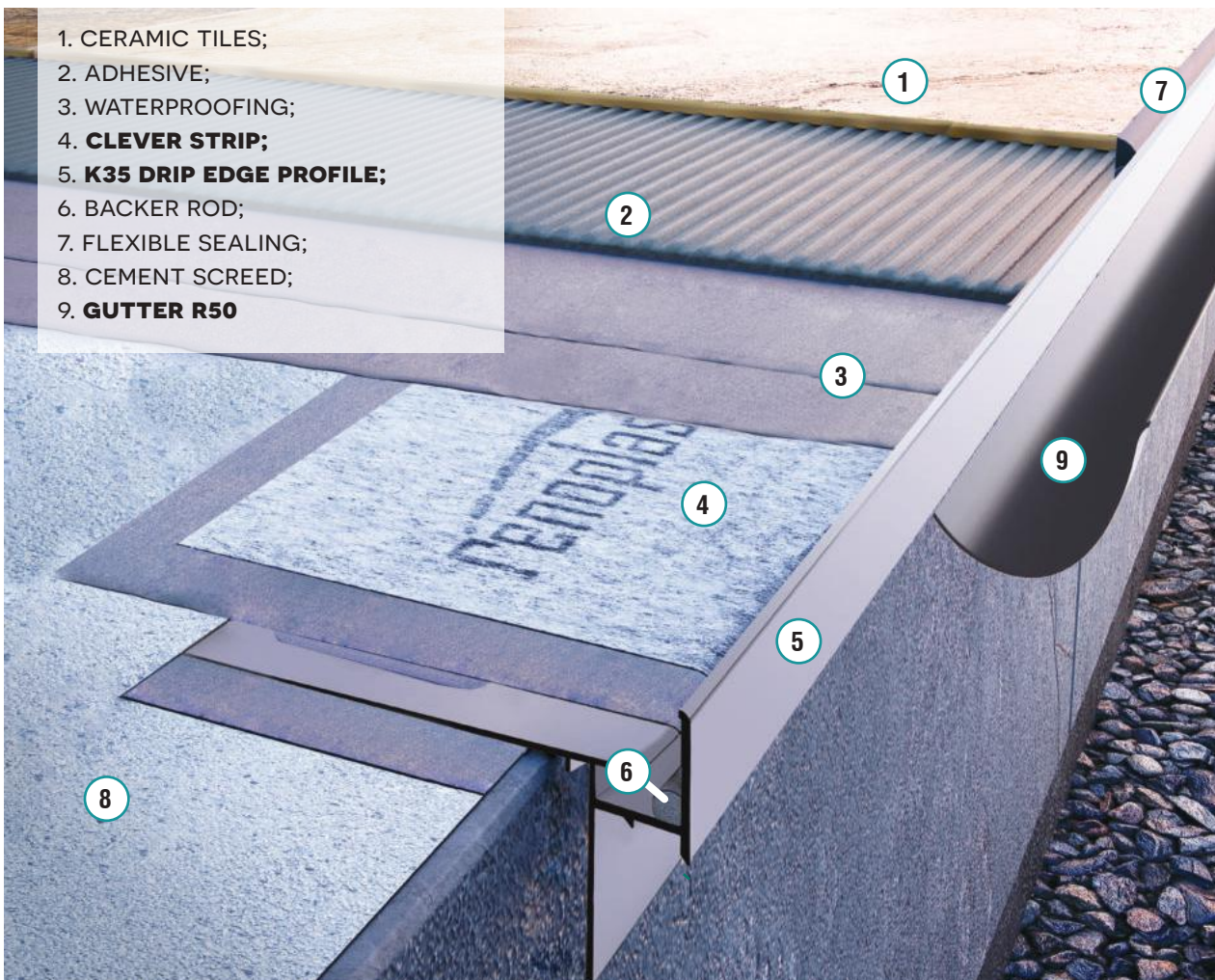

1. CERAMIC TILES;
2. ADHESIVE;
3. WATERPROOFING;
4. **CLEVER STRIP;**
5. **K35 DRIP EDGE PROFILE;**
6. BACKER ROD;
7. FLEXIBLE SEALING;
8. CEMENT SCREED;
9. **GUTTER R50**

**PRO K35 DRIP EDGE PROFILE**



# ECO K100 DRIP EDGE PROFILE



NZ 100/90  
Outside corner 90°/135°



NW 100/90  
Inside corner 90°/135°

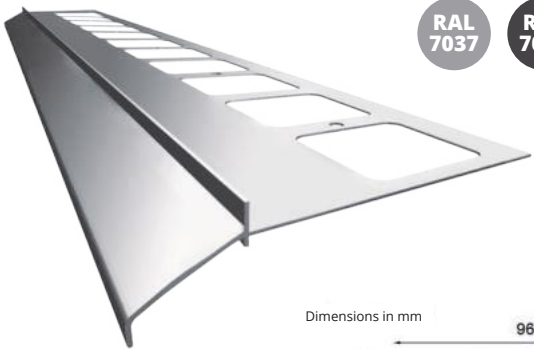

RAL  
7037

RAL  
7024

RAL  
8019

K100 ECO  
Drip edge profile

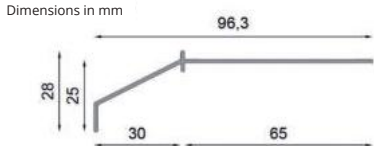

L100  
Connector



OP100  
End stop  
left/right (set)

### ECO K100 PROFILE - DRIP EDGE PROFILE FOR ADHESIVE TILES

- Facilitates efficient water run-off away from the terrace or balcony
- Bended outwards, protruding 3 cm beyond balcony/terrace outer edges.



**INSTRUCTIONAL  
VIDEO  
K100**

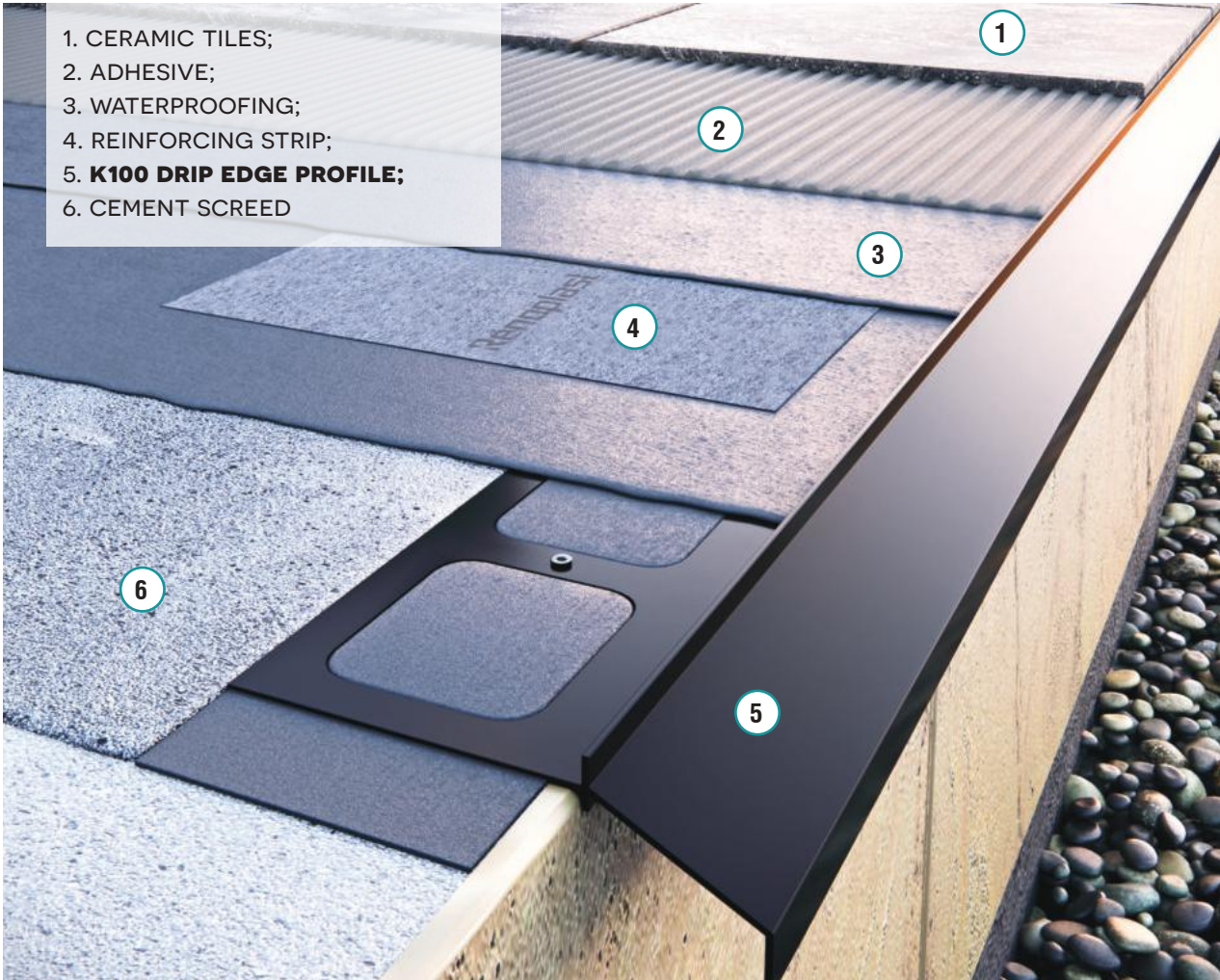

1. CERAMIC TILES;
2. ADHESIVE;
3. WATERPROOFING;
4. REINFORCING STRIP;
5. **K100 DRIP EDGE PROFILE;**
6. CEMENT SCREED

**ECO K100 DRIP EDGE PROFILE**



# ECO+ K100R DRIP EDGE PROFILE



NZ 100R/90  
Outside corner  
90°/135°



NW 100R/90  
Inside corner  
90°/135°

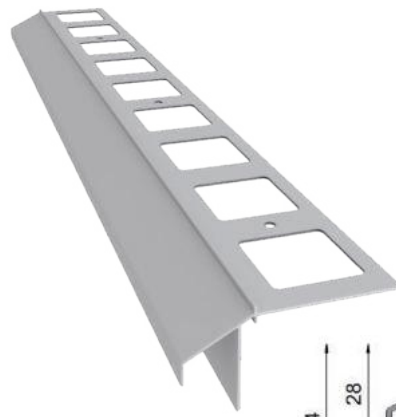

K100R ECO+  
Drip edge profile

RAL  
7037

RAL  
7024

RAL  
8019

Minimal overhang of the K100R profile (without gutter) beyond balcony/terrace outer edges is: **31.3 mm** or **60 mm** with gutter R50.

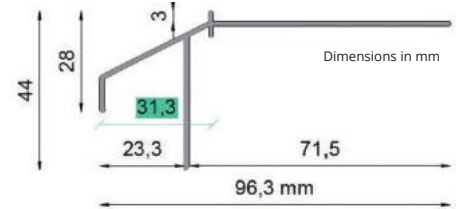

L100R  
Connector



OP100R  
End stop  
left/right (set)



R50  
Aluminium gutter

## ECO+ K100R PROFILE - DRIP EDGE PROFILE FOR ADHESIVE TILES READY FOR ALUMINIUM GUTTER R50 INSTALLATION

- Bended outwards, protruding 3 cm beyond balcony/terrace outer edges
- Designed to allow the installation of the R50 gutters

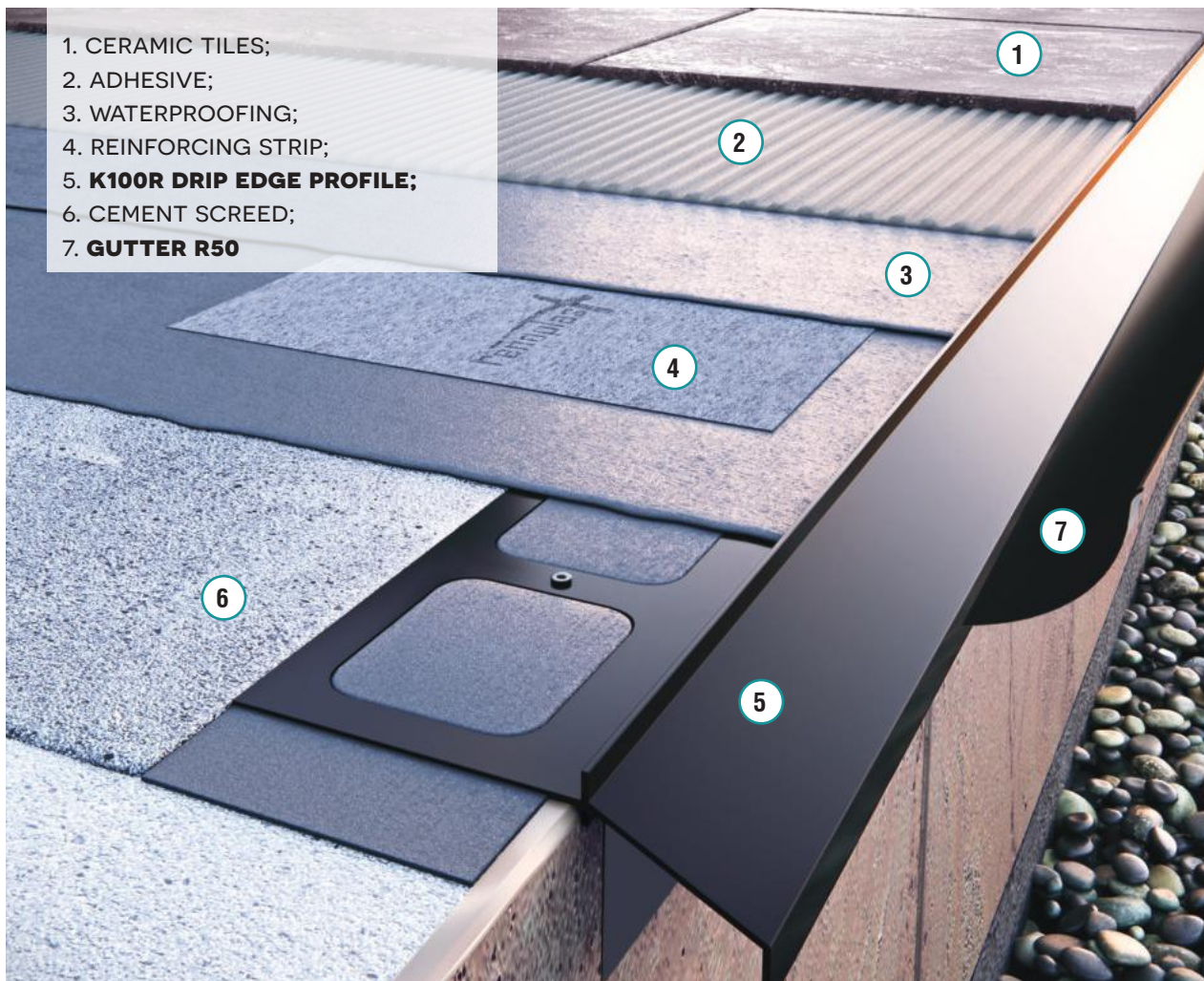

1. CERAMIC TILES;
2. ADHESIVE;
3. WATERPROOFING;
4. REINFORCING STRIP;
5. **K100R DRIP EDGE PROFILE;**
6. CEMENT SCREED;
7. **GUTTER R50**

ECO+ K100R DRIP EDGE PROFILE

# MULTI D25 DRIP EDGE PROFILE

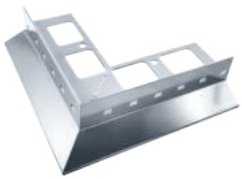

NZ D25/90  
Outside corner 90°/135°

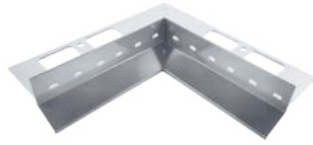

NW D25/90  
Inside corner 90°/135°



RAL 7037 RAL 7024 RAL 8019

D25 MULTI  
Drip edge profile

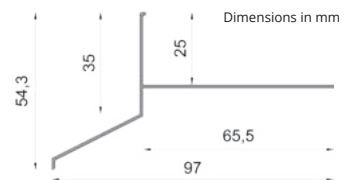

LD25  
Connector



OPD25  
End stop  
left/right (set)

## D25 MULTI PROFILE - PROFILE SUITABLE FOR MULTIPLE APPLICATIONS, FOR RAISED OR BONDED FLOORS

- Features peripheral drainage holes at front edge
- 25 mm high front lip of the profile
- Suitable for composite decking and timber or hick tile flooring with the use of low pedestals (8 mm).

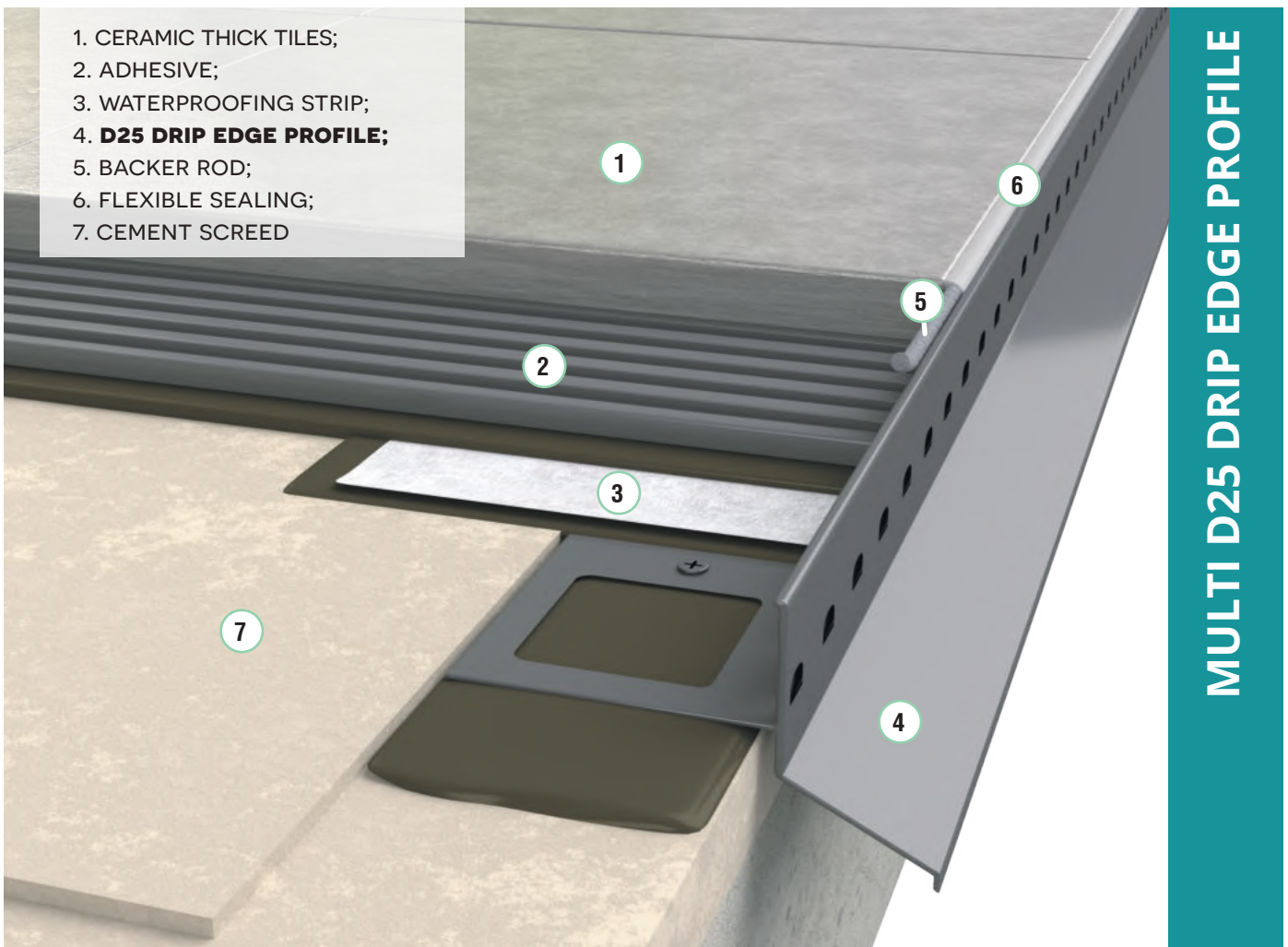

1. CERAMIC THICK TILES;
2. ADHESIVE;
3. WATERPROOFING STRIP;
4. **D25 DRIP EDGE PROFILE;**
5. BACKER ROD;
6. FLEXIBLE SEALING;
7. CEMENT SCREED

MULTI D25 DRIP EDGE PROFILE



# R50 GUTTER SYSTEM INSTALLATION

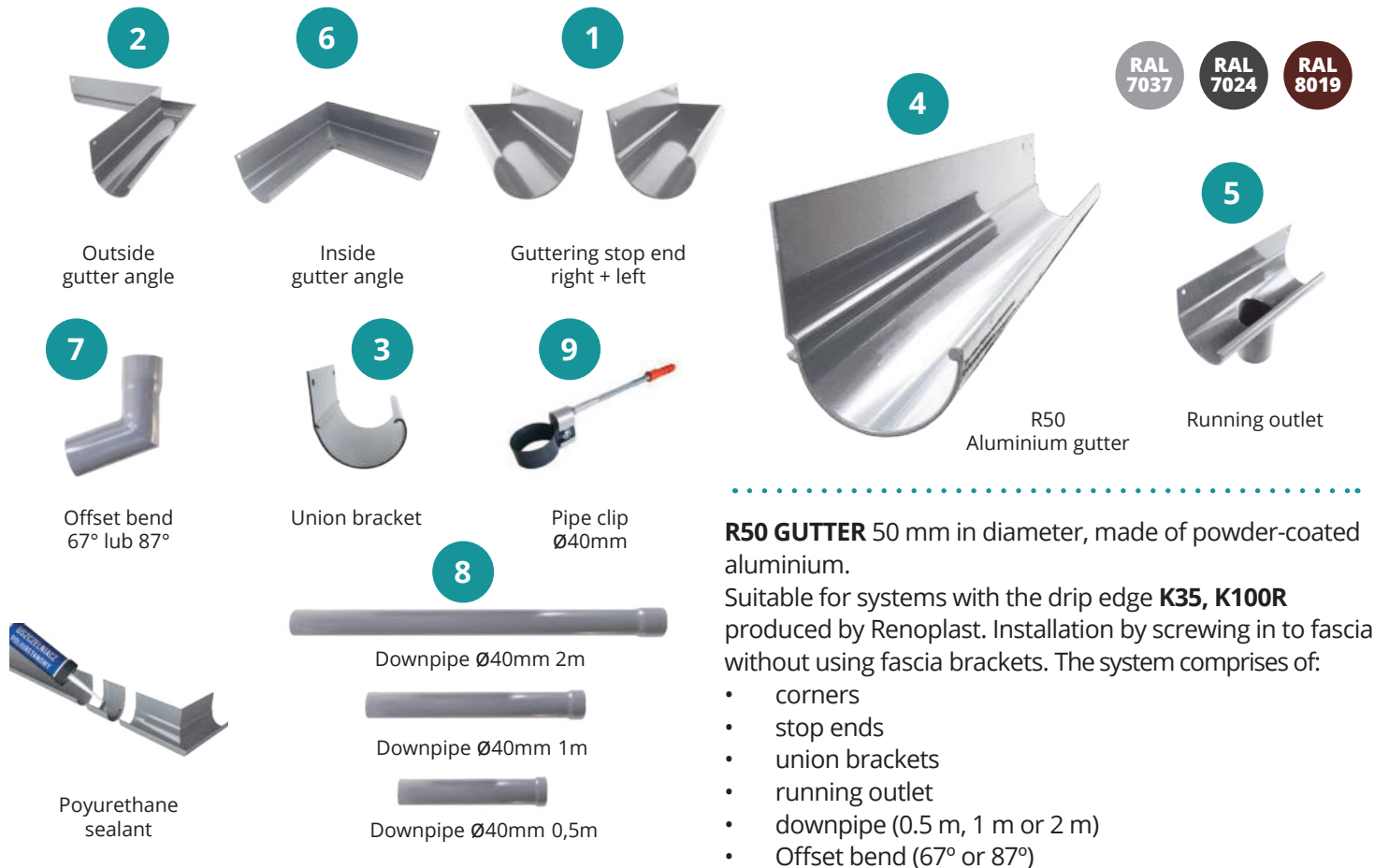

**R50 GUTTER** 50 mm in diameter, made of powder-coated aluminium.

Suitable for systems with the drip edge **K35, K100R** produced by Renoplast. Installation by screwing in to fascia without using fascia brackets. The system comprises of:

- corners
- stop ends
- union brackets
- running outlet
- downpipe (0.5 m, 1 m or 2 m)
- Offset bend (67° or 87°)

## GUTTER ASSEMBLY SCHEME

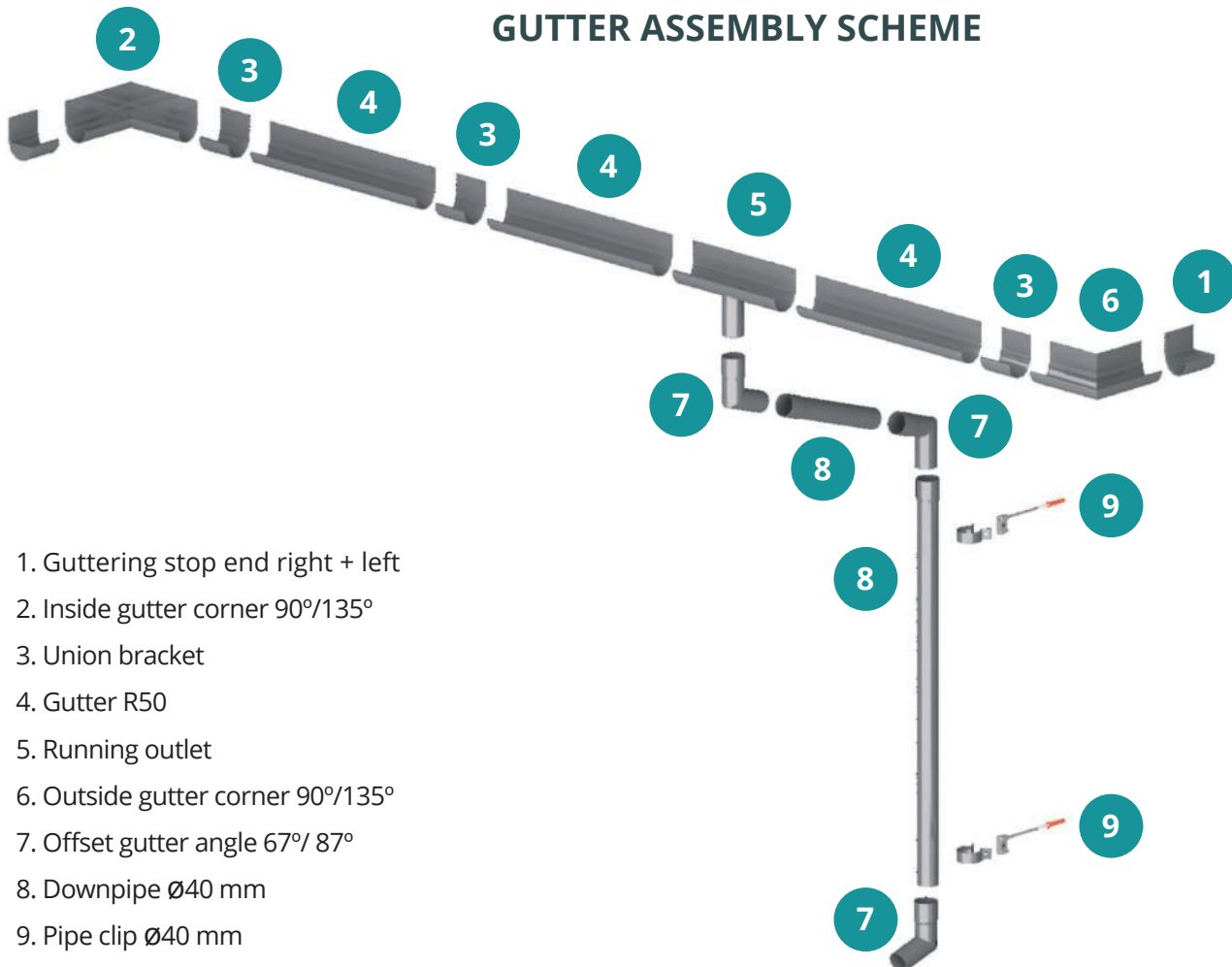

1. Guttering stop end right + left
2. Inside gutter corner 90°/135°
3. Union bracket
4. Gutter R50
5. Running outlet
6. Outside gutter corner 90°/135°
7. Offset gutter angle 67°/ 87°
8. Downpipe Ø40 mm
9. Pipe clip Ø40 mm

R50 GUTTER SYSTEM INSTALLATION

# STEP PROFILE SC1, SC2, SC3

RAL  
7037

RAL  
7024

RAL  
8019

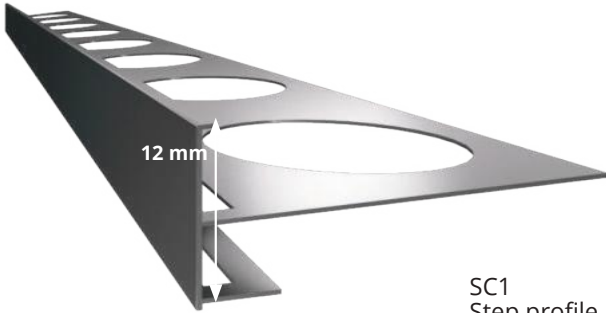

12 mm

SC1  
Step profile

STEP PROFILE FOR  
BEDDED TILES.



SC3  
Step profile

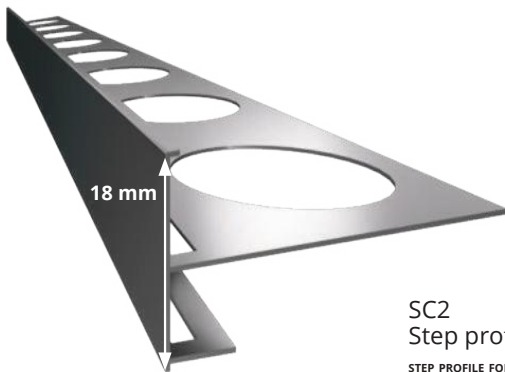

18 mm

SC2  
Step profile

STEP PROFILE FOR  
ADHESIVE THICK TILE.



**INSTRUCTIONAL  
VIDEO  
SC1**

**Profile SC1** (12 mm high) and **SC2** (18 mm high) for external and internal stairs and simple balconies.

- Watertight joint with flooring
- Water run-off from drip area
- Watertight seal around balcony/terrace drip edges
- Guiding water away from surfaces under flooring

**SC3 - TILED STAIR PROFILE FOR FINISHING STRINGERS AND BASEBOARD**

- Watertight joint with flooring
- Water run-off from drip area
- Watertight seal around balcony/terrace drip edges
- Channels moisture away from under the flooring and external stairs

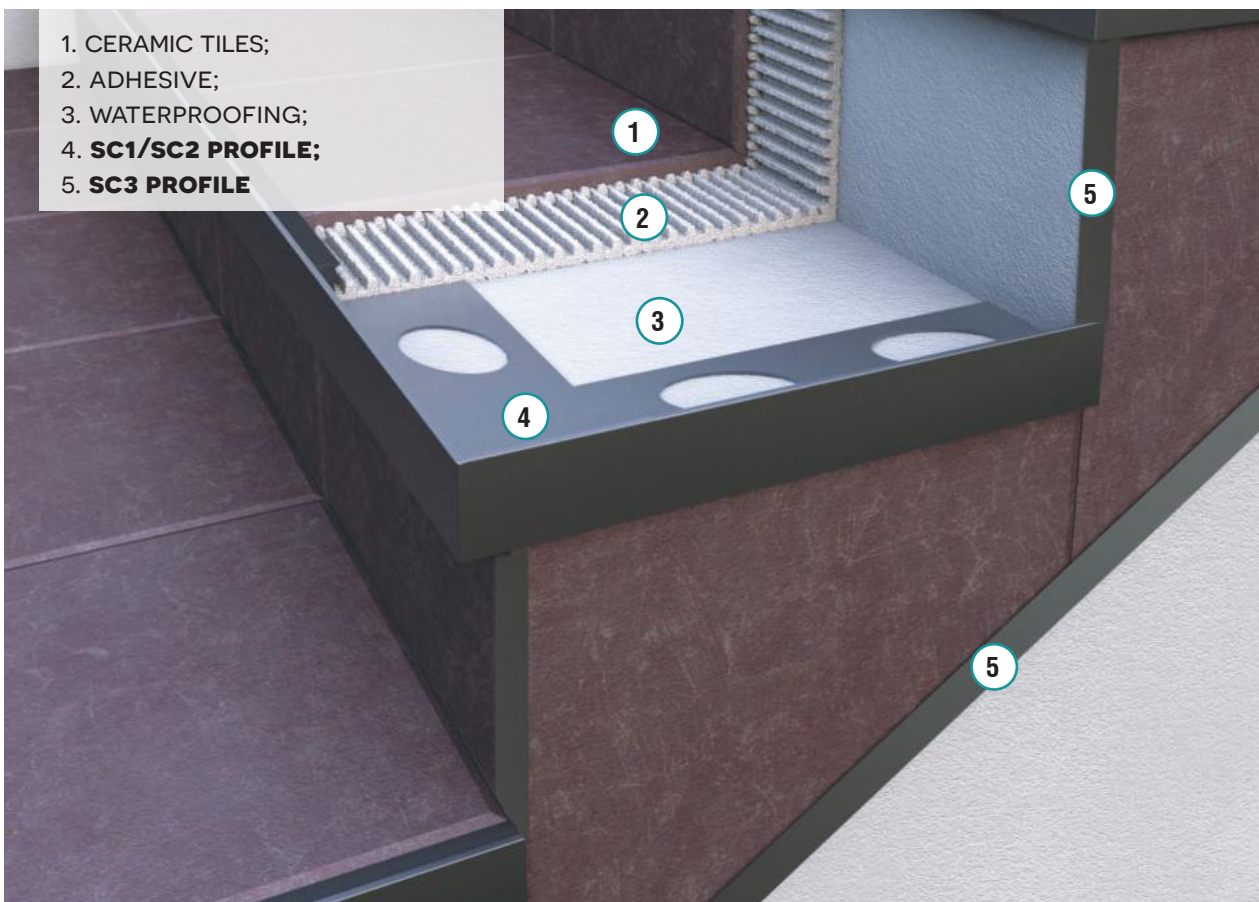

1. CERAMIC TILES;
2. ADHESIVE;
3. WATERPROOFING;
4. **SC1/SC2 PROFILE;**
5. **SC3 PROFILE**

**STEP PROFILE SC1, SC2, SC3**



# ANCILLARY MATERIALS

RAL 7037 RAL 7024 RAL 8019



**MG75 GUTTER BRACKET**

1 set = 4 pcs brackets MG75  
+ 8 pcs screws W13  
Suitable for the Marley,  
Gamrat gutter systems

RAL 7037 RAL 7024 RAL 8019



**G75 GUTTER BRACKET**

1 set = 4 pcs brackets G75  
+ 8 pcs screws W13  
Suitable for the Bryza, Gamrat  
gutter systems



**BACKER ROD Ø 6**

10 m



**S80  
MOULD/STAMP**

2 m (80 cm wide)



**CLEVER  
WATERPROOFING STRIP**

12 cm wide for K102 profile  
16 cm wide for K35 profile



**PL3  
REINFORCING STRIP**

50 m (12 cm wide)



**PL3B  
STEP TAPE WITH  
BUTYL STRIP**

10 m (12 cm wide)



**NW PL3  
INSIDE SEALING CORNER**



**NZ PL3  
OUTSIDE SEALING CORNER**

# QUICK INSTALLATION GUIDE - K102 DRIP EDGE PROFILE

This guide provides general guidelines and is for reference only. Always refer to the instructions of the adhesive/grout/waterproofing/sealant manufacturer. Application conditions (substrate and ambient humidity, application and storage temperature, setting time of each coating, mixing ratios, etc.) must be strictly observed.

1

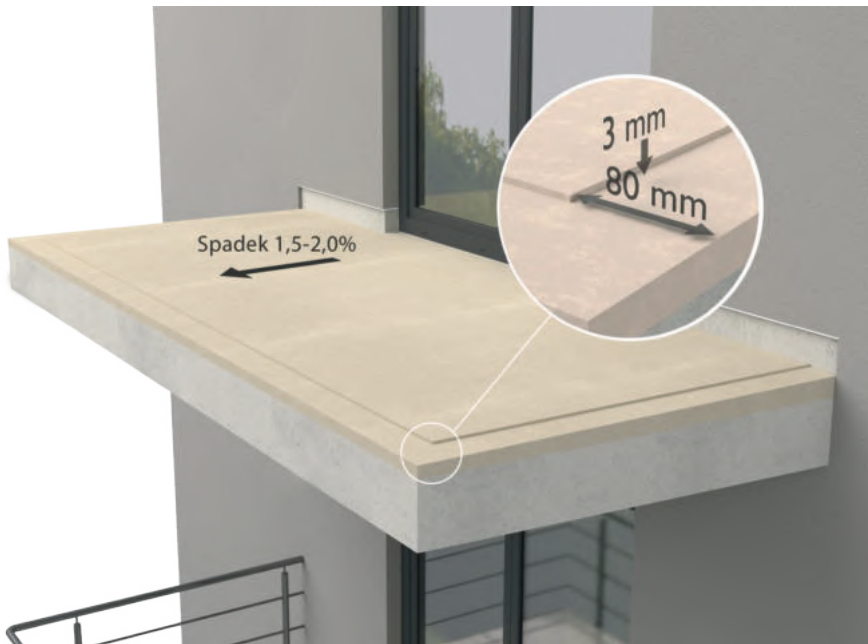

## Balcony or terrace screed

Balcony or terrace screed should be even and sound and have a 1.5 - 2 % slope towards the front edge. It is recommended that a 80 mm wide peripheral drop/indentation in the screed is formed to the depth of 3 mm to allow for the profile to be installed flush with the screed surface.

2



## Initial corners installation

Start with a mock installation of the corners. Put the corners in place to mark the location of the anchors, drill holes, insert the anchors in the mounting holes and fix the **NZ K102/90** corners.



### Cutting profiles

Measure straight sections to cut the **K102** profiles. Make sure that a minimum 2 mm gap is left in between the profiles at their joints as well as at the connection with the wall to allow for the end stop **OPK102**. Cut the profiles using a hand or power saw for cutting aluminium. Angle grinder must not be used as it can lead to local overheating and damage to the paint coating.

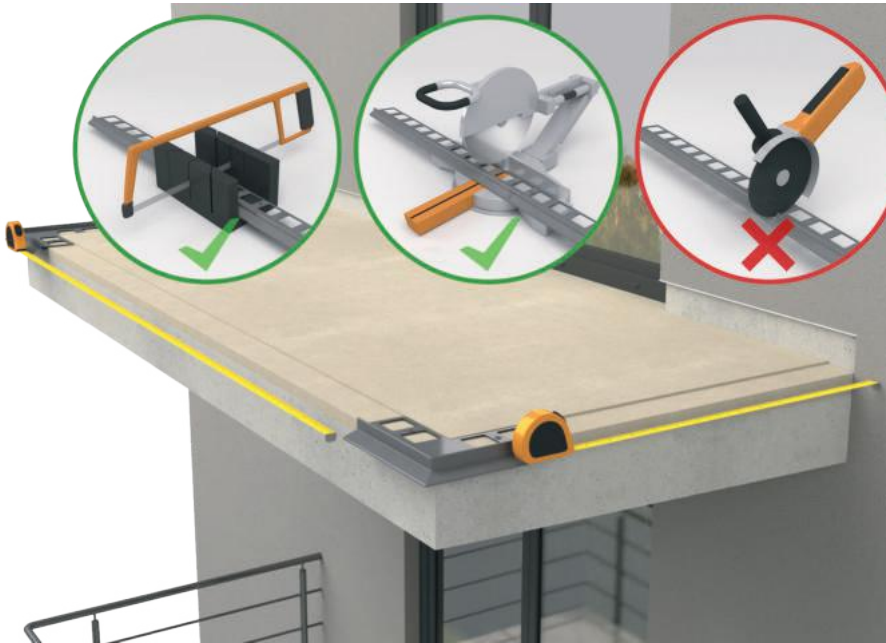

### Drilling mounting holes

Place the **K102** straight profiles, cut to the desired length, mark drill holes, drill the holes, then remove any dust and debris and insert dowel sleeves in the mounting holes.

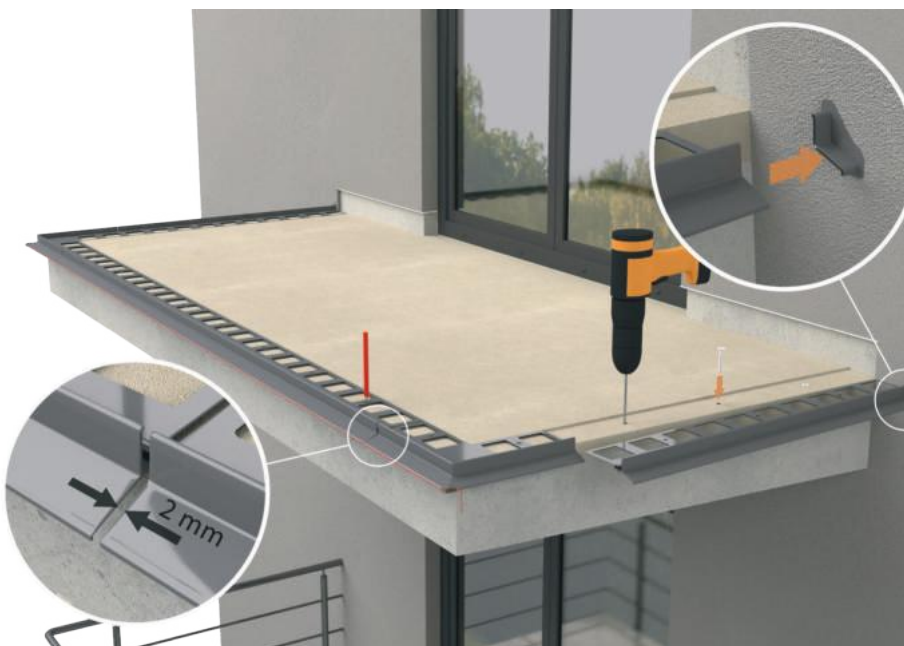

### Corners installation

First, embed the **NZ K102/90** corners in the waterproofing and fix them to the substrate using dowels.



### Installation of straight profiles

Insert the waterproofing tape **Renoplast Clever** into the slot in the profile, allowing for overlap. Installation procedure for the **K102** straight profiles is the same as for the corners. Use builder's line stretched between the corners and a spirit level to ensure that they are aligned and flush.

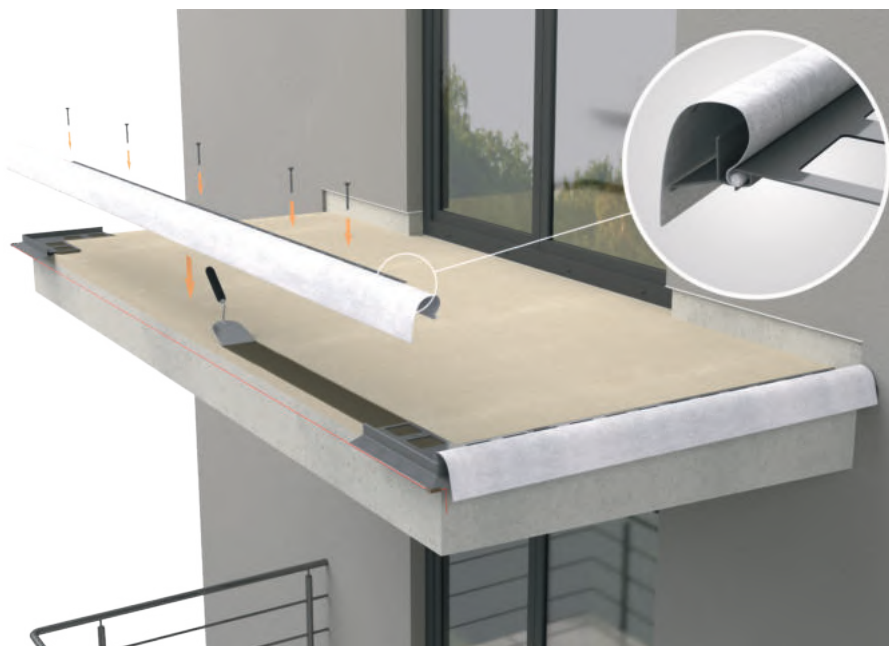



7

### Connectors installation

Snap on the connectors **Renoplast LK102** in place. Tighten the dowels carefully, making sure that the waterproofing does not ooze out from under the profiles. Where necessary, add or remove excess material. Allow to set.



8

### Connection of profiles with balcony/terrace screed

To reinforce the connection between the perforated anchoring leg of **Renoplast K102** and the screed and to seal it, press the **Renoplast Clever waterproofing strip** in the waterproofing compound. To seal the joint with the doorstep use the door sealing tape with **butyl strip Renoplast PL3**.



9

### Waterproofing application

Spread the waterproof compound over the screed as instructed in the technical data sheet of the waterproofing.

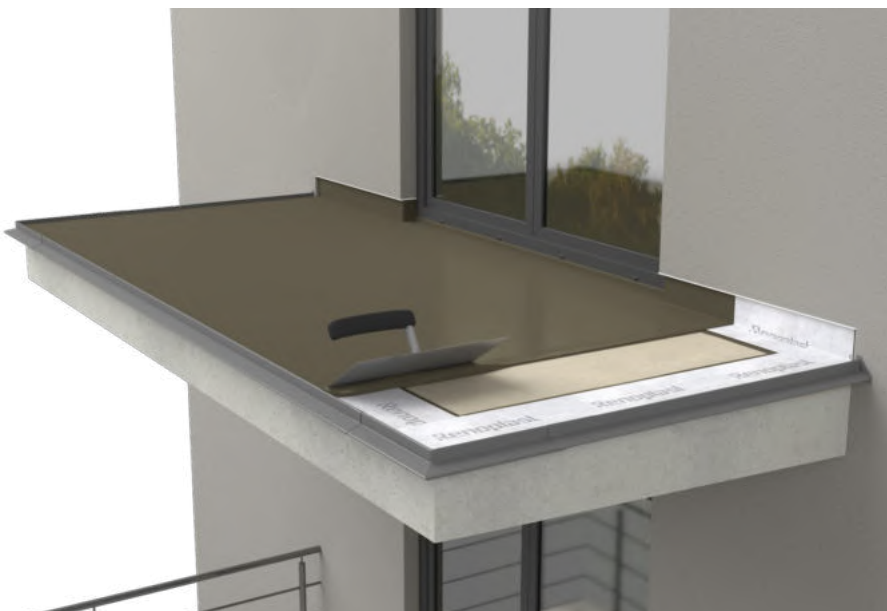

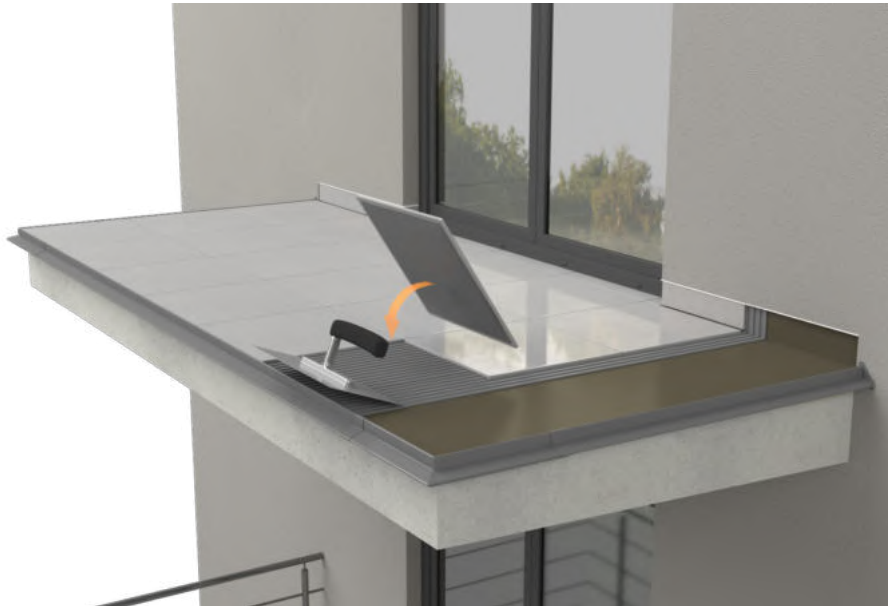

**Tiling/Paving** Lay the tiles over waterproofing layer on suitable adhesive (min. C2-S1). Make sure that a minimum 5 mm gap is left between the tile edging upper lip and the tiles. A gap should also be left at the interface with the skirting and with the door.

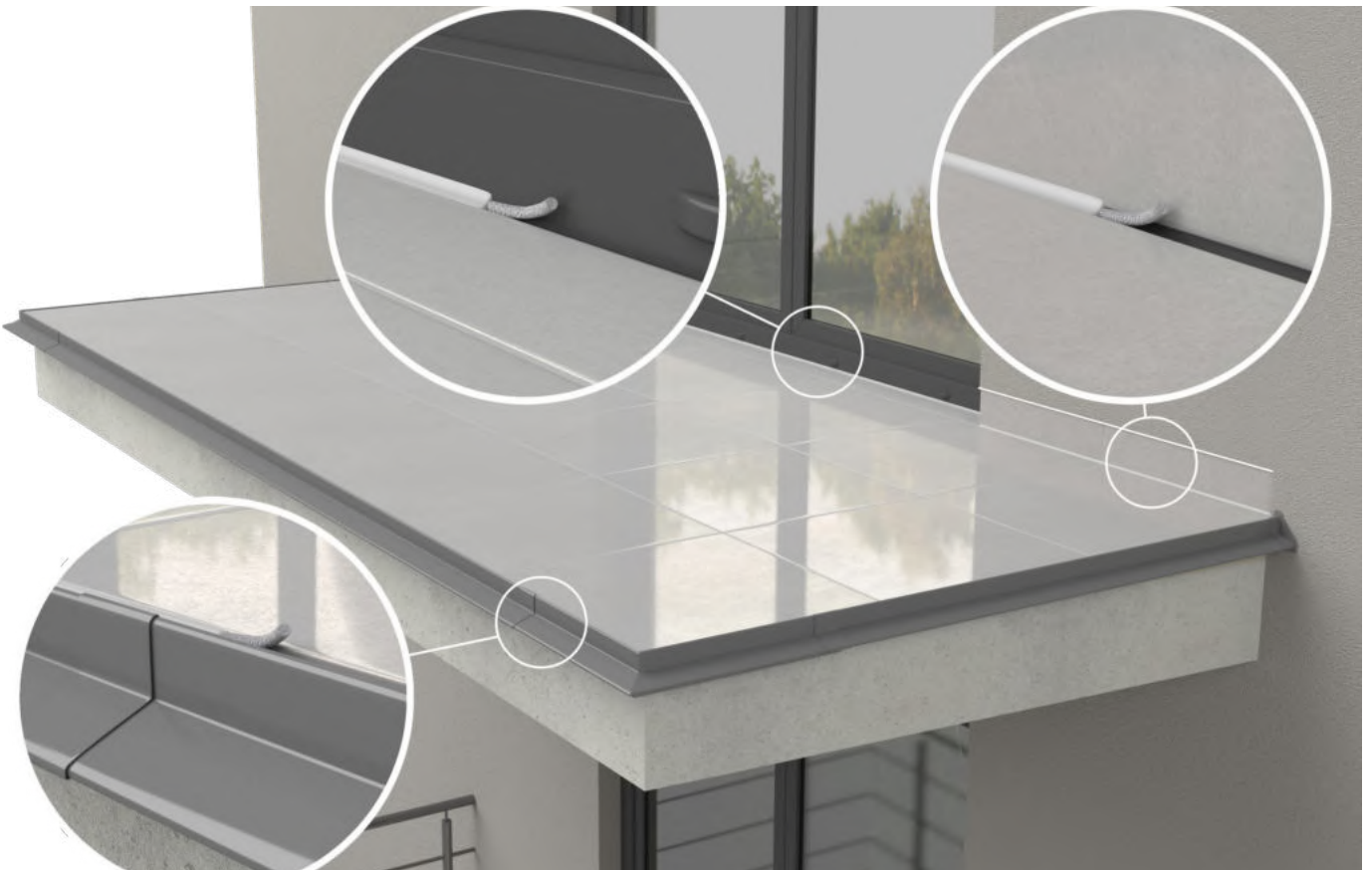

#### **Installation of flexible joint along the drip edge profile**

Insert  $\phi 6$  mm backer rod into the gaps along the **K102** profiles, skirting and door and then seal the gaps from the top using an elastic sealing compound for exterior applications e.g. PU sealant.



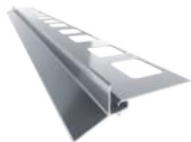
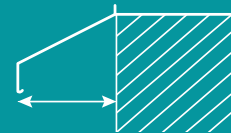

**K102 OPTIMAL**  
P. 8

FULL DRIP EDGE PROTECTION WITH MOISTURE DRAINAGE



MOŻLIWOŚĆ WYKONANIA PROFILU W ŁUKU NA ZAMÓWIENIE

45 MM

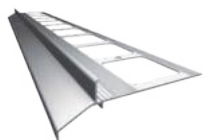

**K30 BASIC**  
P.9

FULL DRIP EDGE PROTECTION WITH MOISTURE DRAINAGE



CUSTOMISED CURVED PROFILES ARE AVAILABLE TO ORDER

30 MM

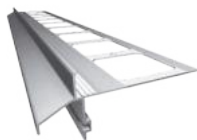

**K40 BASIC+**  
P. 10

FULL DRIP EDGE PROTECTION WITH MOISTURE DRAINAGE

PVC 75 MM



60 MM



**K301 SIMPLE**  
P. 11



CUSTOMISED CURVED PROFILES ARE AVAILABLE TO ORDER

30 MM



**K35 PRO**  
P. 12

FULL DRIP EDGE PROTECTION WITH MOISTURE DRAINAGE

ALUMINIUM GUTTER R50 RENOPLAST

CUSTOMISED CURVED PROFILES ARE AVAILABLE TO ORDER

30 MM  
65 MM (WITH GUTTER R50)

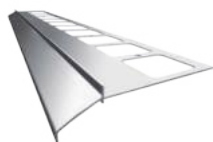

**K100 ECO**  
P. 13



CUSTOMISED CURVED PROFILES ARE AVAILABLE TO ORDER

40 MM



**K100R ECO+**  
P. 14



ALUMINIUM GUTTER R50 RENOPLAST



32 MM  
65 MM (WITH GUTTER R50)











# RAISED FLOOR





## PROBLEMS

**CORROSION OF DRIP RAIL**



**INEFFICIENT WATER  
RUN-OFF**



**NO PROPER FINISHING OF  
DRIP EDGES AND SUPPORT  
FOR EDGING PROFILES**



**STRESS LEADING TO TILE  
CRACKING**



# SOLUTION

## ANTI-CORROSION

All Renoplast profiles are coated compliant with the highest world standards which is Qualicoat-certified.

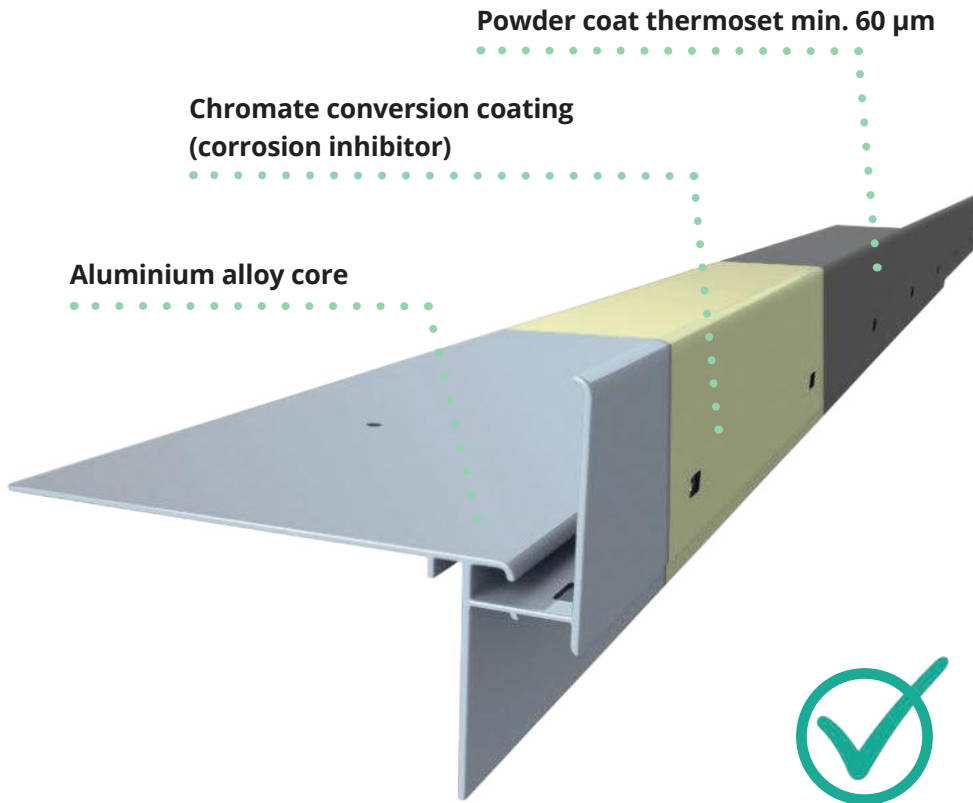

## EFFICIENT WATER RUN-OFF



A unique feature of the Renoplast profiles are large drainage holes that are installed beneath the waterproofing. The profiles also features emergency overflow holes that, in the case the main drainage holes are clogged, drain water, informing the user that the main drainage holes must be cleared up.



## COMPLETE SYSTEM

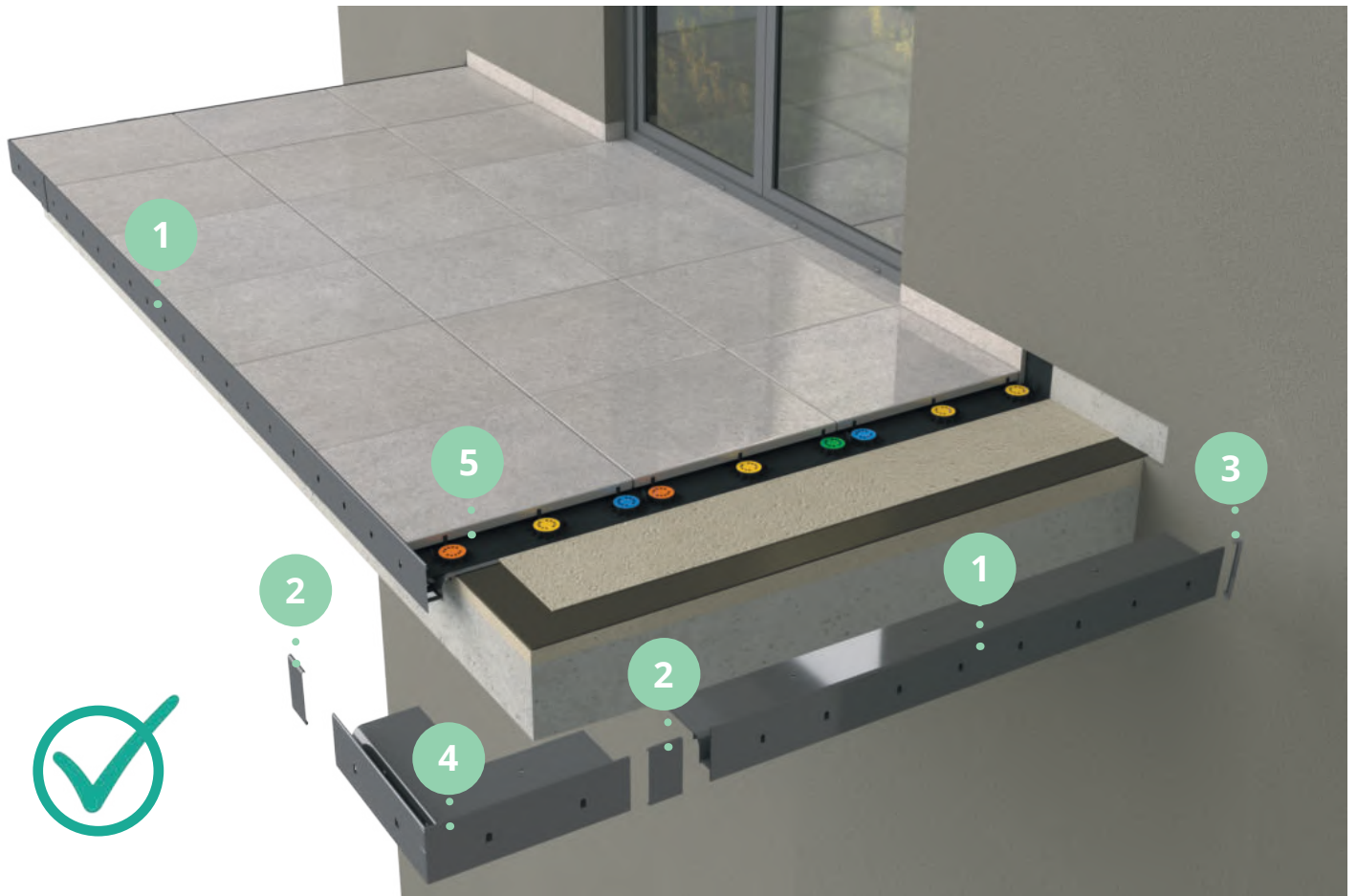

We offer straight profiles (1), connectors (2), end stops (3) and outside and inside corners (4) - of standard 90° and 135° angles. Customised angle corners and curved balcony profiles are also made to order.

## FIRM AND STABLE SUPPORT FOR TILES

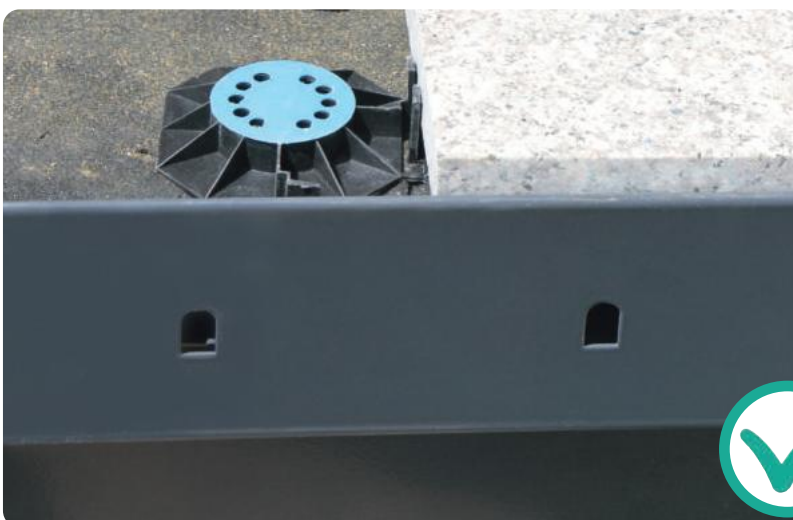

Except for the main function a drip profile performs i.e. efficient water shedding, it also provides a tile retaining edge to stabilise the tiles and prevent them from slipping or falling off. Drip profiles and pedestals then must be designed and produced as part of an integrated system to ensure compatibility which is guaranteed by the Renoplast systems.

# BASIC W30 DRIP EDGE PROFILE



NZ W30/90  
Outside corner 90°/135°



NW W30/90  
Inside corner 90°/135°



LW30  
Connector



OPW30  
End stop  
left/right  
(set)



W30 BASIC  
Drip edge profile

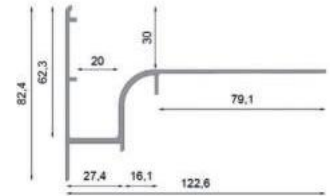

RAL  
7037

RAL  
7024

RAL  
8019

## BASIC W30 PROFILE - EDGING PROFILE FOR RAISED FLOORS WITH LARGE DRAINAGE HOLES

- Large drainage holes
- Tile retaining edge to provide a stable support for pavers
- Special extra drainage system of overflow holes located on the front of the profile to provide extra drainage.



**INSTRUCTIONAL  
VIDEO  
W30**

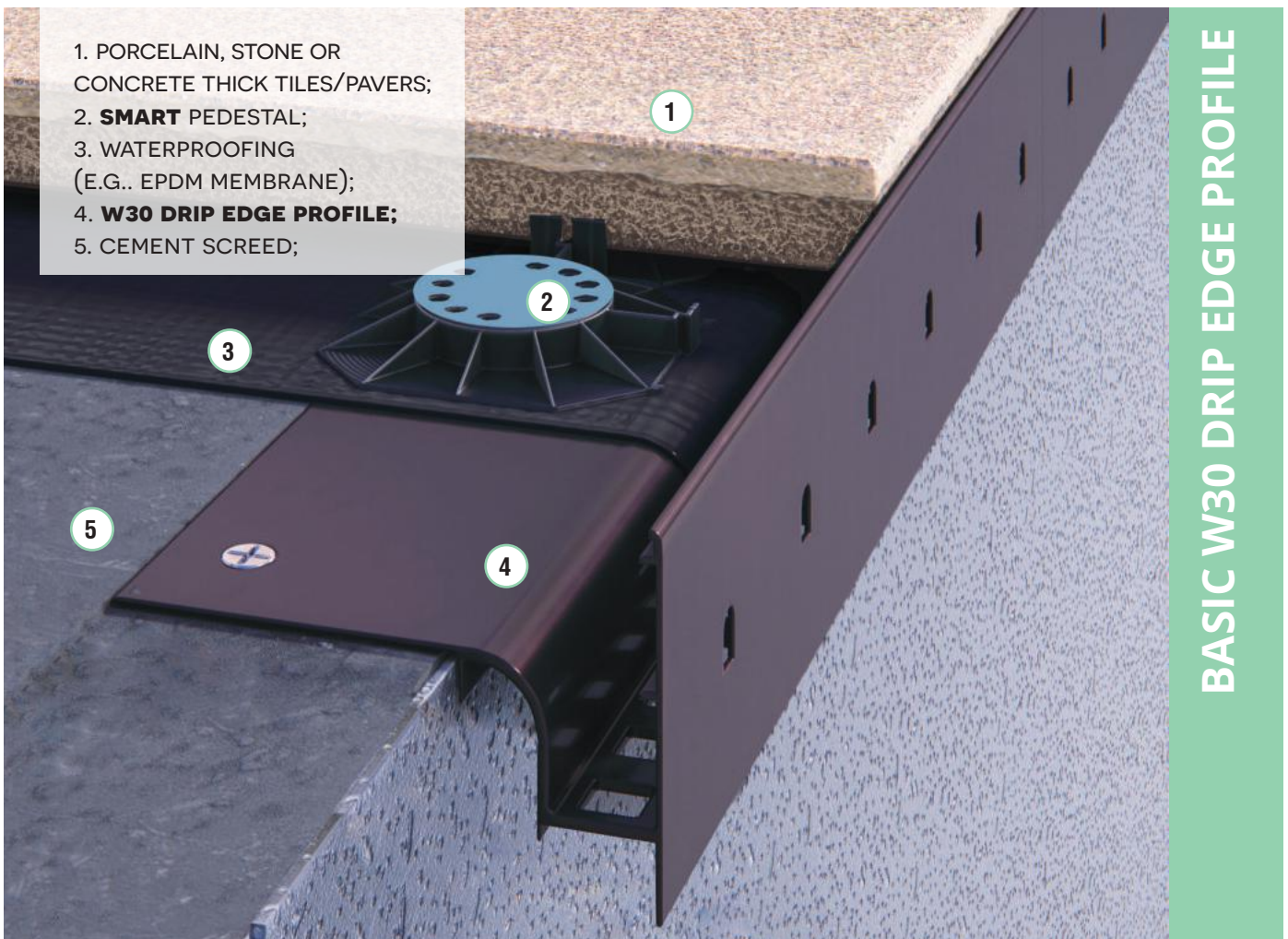

1. PORCELAIN, STONE OR CONCRETE THICK TILES/PAVERS;
2. **SMART** PEDESTAL;
3. WATERPROOFING (E.G.. EPDM MEMBRANE);
4. **W30 DRIP EDGE PROFILE**;
5. CEMENT SCREED;

**BASIC W30 DRIP EDGE PROFILE**



# BASIC+ W30R DRIP EDGE PROFILE



NZ W30R/90  
Outside  
corner 90°/135°



NW W30R/90  
Inside  
corner 90°/135°



OPW30R  
End stop  
left/right  
(set)



W30R BASIC+  
Drip edge profile

RAL  
7037

RAL  
7024

RAL  
8019

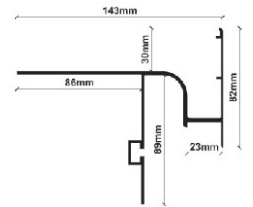

LW30R  
Connector



MG75  
Gutter bracket



G75  
Gutter bracket

## W30R BASIC+ PROFILE - EDGING PROFILE FOR RAISED FLOORS WITH LARGE DRAINAGE HOLES READY FOR 75 MM PVC GUTTER INSTALLATION

- Large drainage holes
- Tile retaining edge to provide a stable support for pavers
- Special extra drainage system of overflow holes located on the front of the profile to provide extra drainage.
- Designed to allow the installation of PVC gutters.



**INSTRUCTIONAL  
VIDEO  
W30**

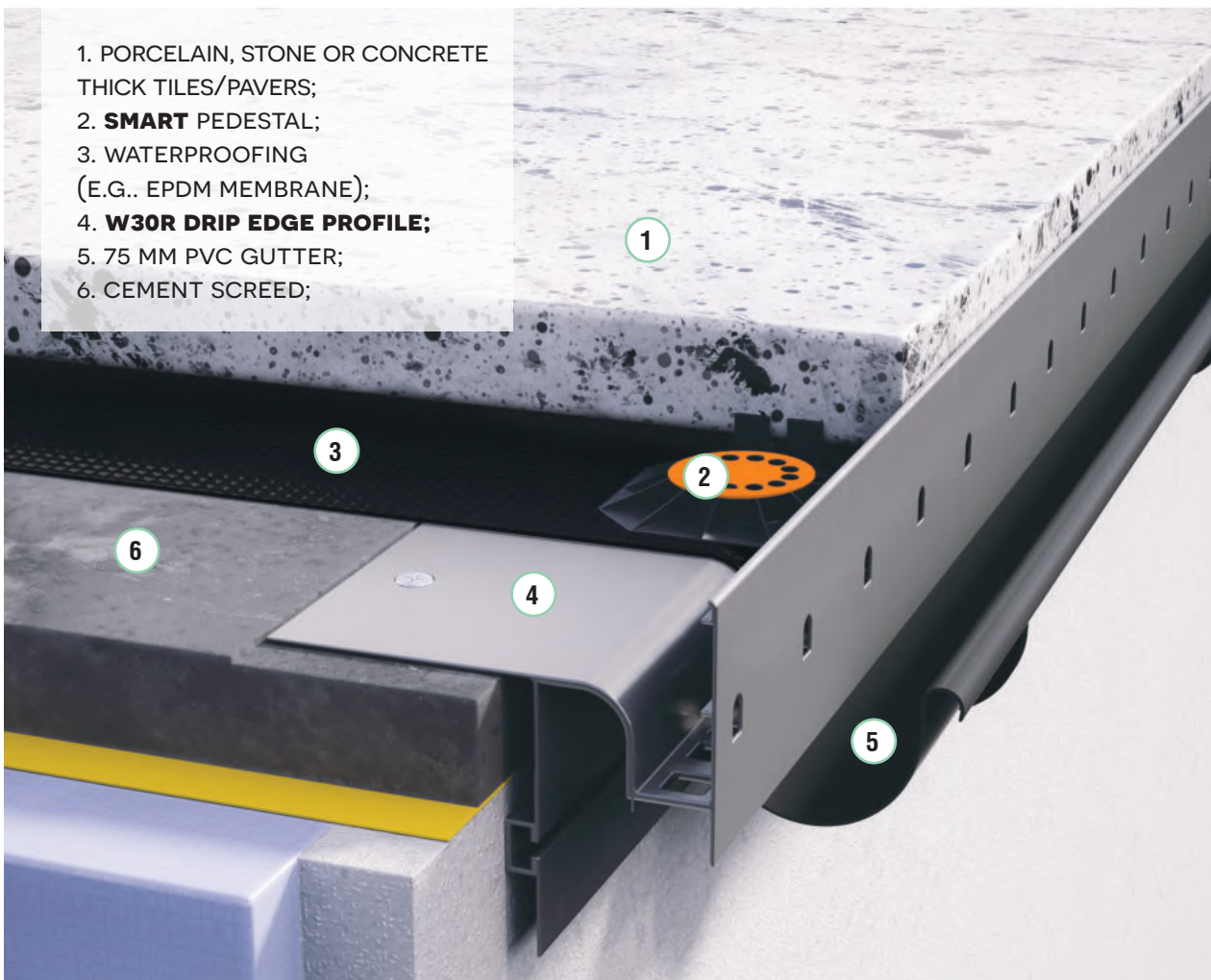

1. PORCELAIN, STONE OR CONCRETE THICK TILES/PAVERS;
2. **SMART** PEDESTAL;
3. WATERPROOFING (E.G.. EPDM MEMBRANE);
4. **W30R DRIP EDGE PROFILE;**
5. 75 MM PVC GUTTER;
6. CEMENT SCREED;

**BASIC+ W30R DRIP EDGE PROFILE**

# PRO W35+ DRIP EDGE PROFILE



NZ W35+/90  
Outside  
corner 90°/135°



NW W35+/90  
Inside  
corner 90°/135°



Side profile  
W35B



W35+ PRO  
Drip edge profile

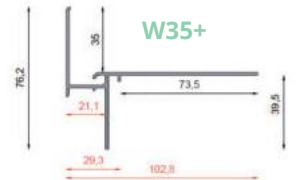

LW35+  
Connector



LW35B  
Connector



Corner connecting  
side profile  
with straight profile



OPW35+  
End stop  
left/right  
(set)



OPW35B  
End stop  
left/right  
(set)



R50  
Gutter system

**W35+ PRO PROFILE - EDGE PROFILE ALLOWING FOR CONNECTION WITH WATERPROOFING USING WATERPROOFING STRIP OR PVC SEALING STRIP READY FOR ALUMINIUM GUTTER R50 INSTALLATION**

Special extra drainage system of overflow holes located on the front of the profile to provide extra drainage.

- Designed to allow the installation of the aluminium R50 gutters
- Tile retaining edge to provide a stable support for pavers/tiles.

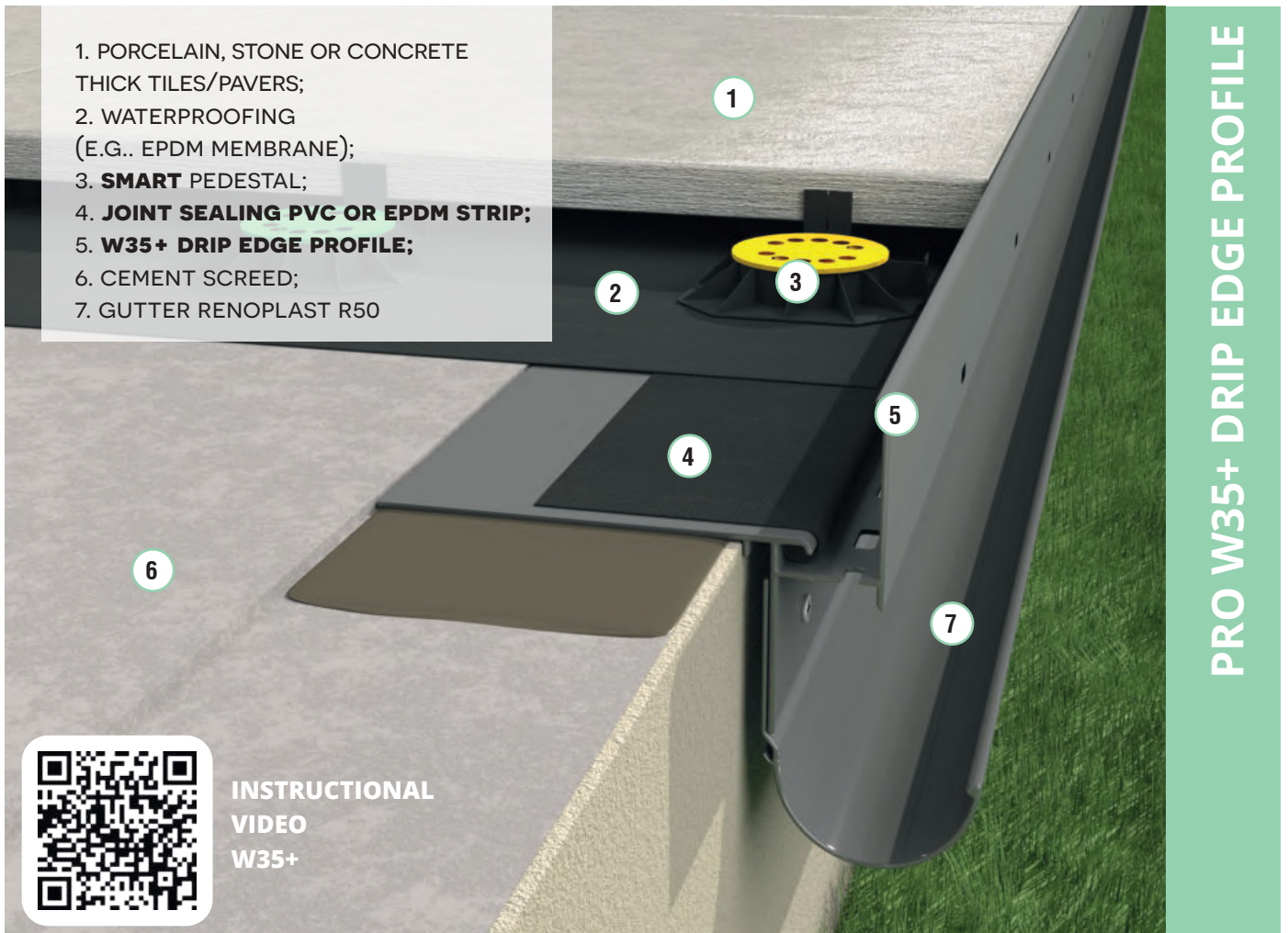

1. PORCELAIN, STONE OR CONCRETE THICK TILES/PAVERS;
2. WATERPROOFING (E.G.. EPDM MEMBRANE);
3. **SMART** PEDESTAL;
4. **JOINT SEALING PVC OR EPDM STRIP;**
5. **W35+ DRIP EDGE PROFILE;**
6. CEMENT SCREED;
7. GUTTER RENOPLAST R50

PRO W35+ DRIP EDGE PROFILE



INSTRUCTIONAL  
VIDEO  
W35+



# GRAND K60 DRIP EDGE PROFILE



NZ 60/90  
Outside  
corner 90°/135°



NW 60/90  
Inside  
corner 90°/135°



OP60  
End stop  
left/right  
(set)



L60  
Connector



MG75  
Gutter bracket



G75  
Gutter bracket



K60 GRAND  
Drip edge profile

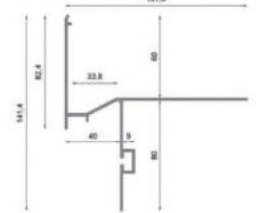

**K60 GRAND PROFILE- EDGING PROFILE FOR DECKING BOARDS OR CONCRETE SLABS READY FOR 75 MM PVC GUTTER INSTALLATION**

Suitable for the systems:

- Raised floor with ceramic, stone or concrete pavers 4 to 5 cm high, on pedestals
- Dry installation, stone or concrete slabs laid in gravel/stone bed with drainage mat T50
- Decking boards installed on joists
- Ready for the installation of 75 mm PVC gutters using fascia brackets MG75/G75.



**INSTRUCTIONAL  
VIDEO  
K60**

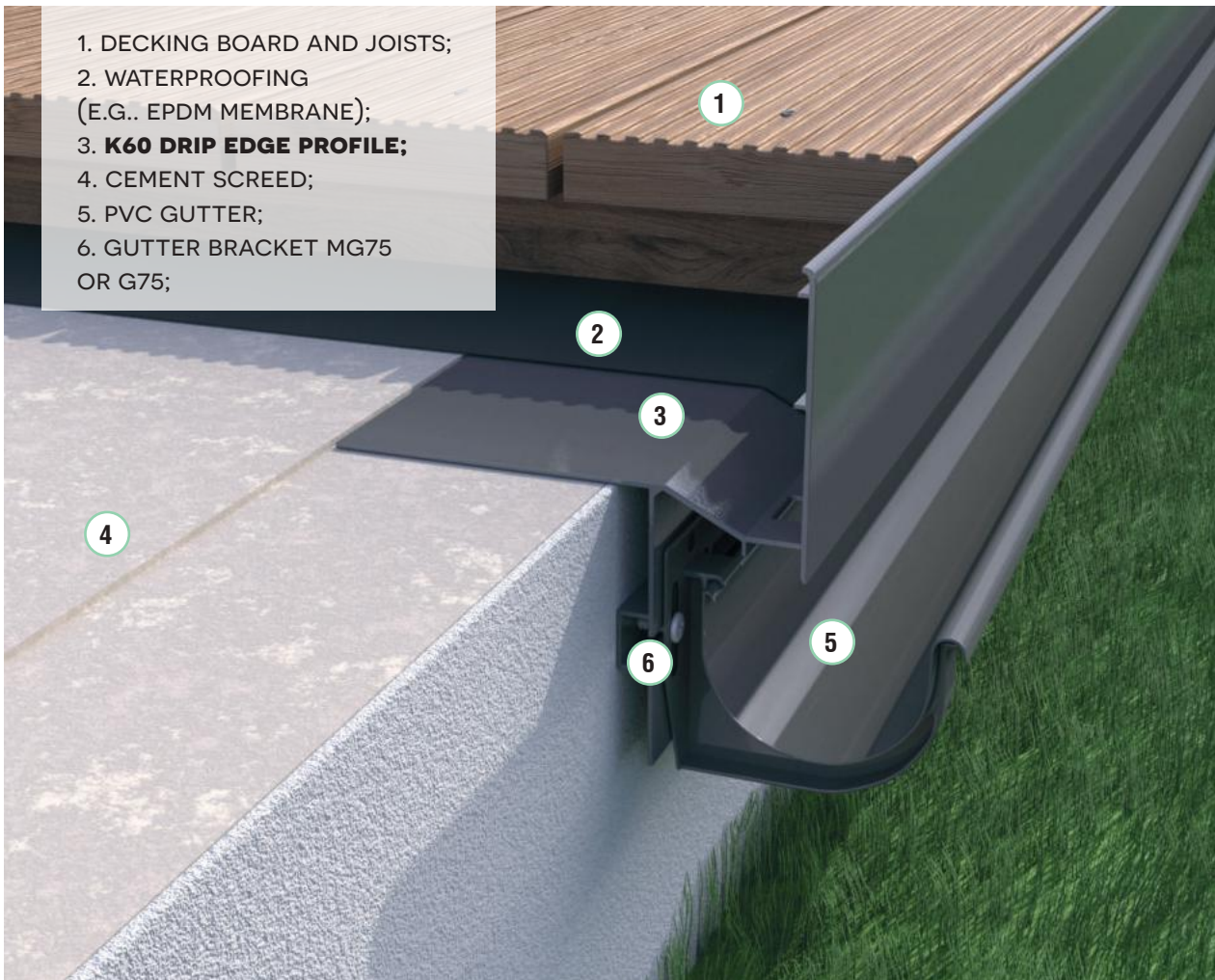

1. DECKING BOARD AND JOISTS;
2. WATERPROOFING (E.G.. EPDM MEMBRANE);
3. **K60 DRIP EDGE PROFILE;**
4. CEMENT SCREED;
5. PVC GUTTER;
6. GUTTER BRACKET MG75 OR G75;

**GRAND K60 DRIP EDGE PROFILE**

# UNIVERSAL W10 DRIP EDGE PROFILE

RAL 7037

RAL 7024

RAL 8019



NZ W10/90  
Outside  
corner 90°/135°



NW W10/90  
Inside  
corner 90°/135°



OPW10  
End stop  
left/right  
(set)



W10 UNIWERSAL  
Drip edge profile



LW10  
Connector



W10Z  
Top profile



NZ W10Z/90  
Outside  
corner 90°

## W10 UNIVERSAL PROFILE - EDGING PROFILE DESIGNED TO MASK TERRACE FRONT EDGE WITH 10 MM TILE, ON RENOPAD PEDESTALS

- It allows masking of the terrace front with paving slabs, tiles, HPL panels or fibrecement slates 10 mm thick
- When used with the RENOPLAST pedestals it allows raising the floor level by 20 cm.

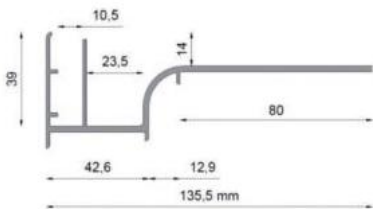

Minimal overhang of the W10 profile beyond balcony/terrace outer edges is **56 mm**.

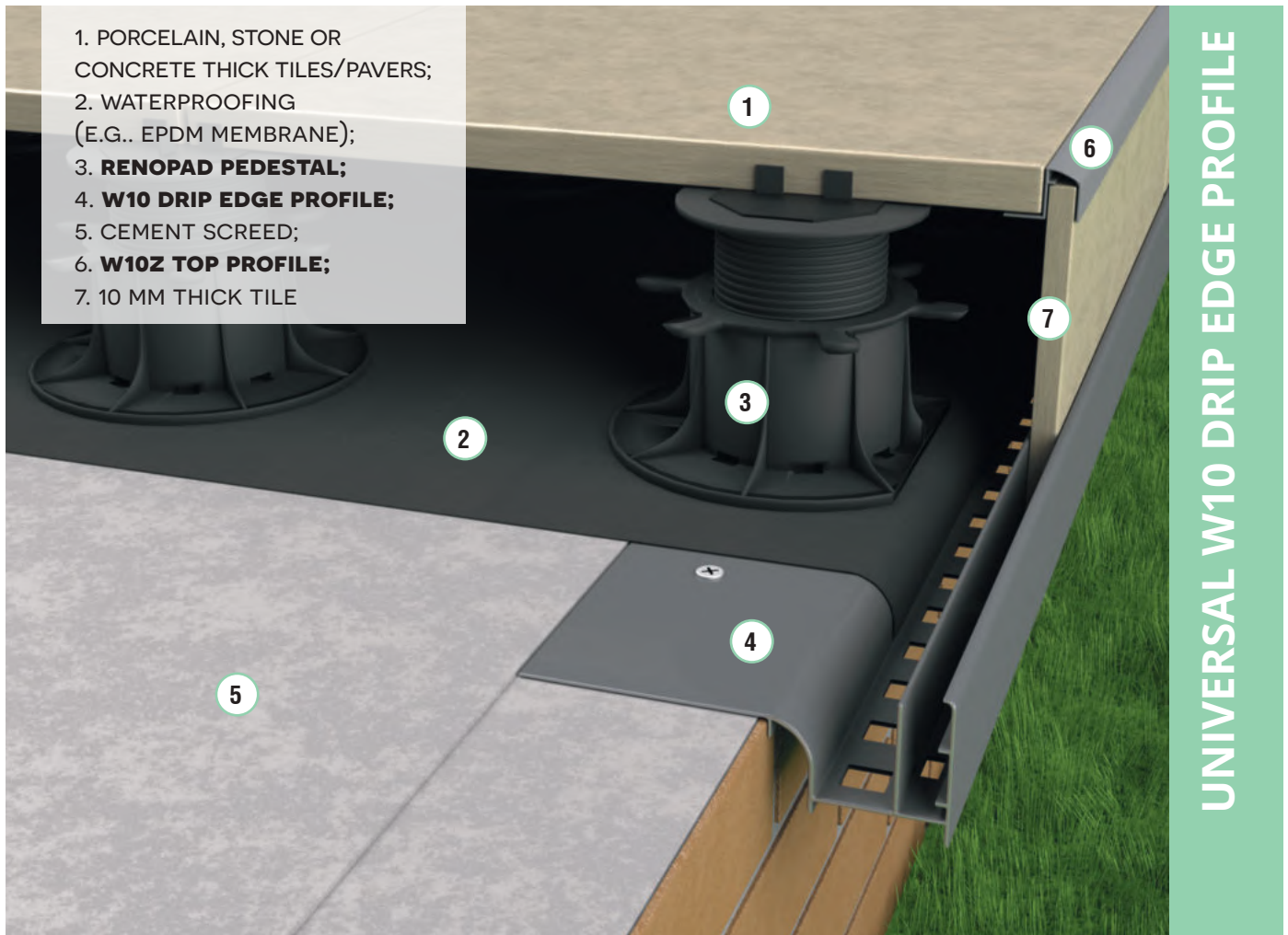

UNIVERSAL W10 DRIP EDGE PROFILE



# UNIVERSAL W20 DRIP EDGE PROFILE

RAL 7037

RAL 7024

RAL 8019

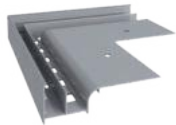

NZ W20/90  
Outside  
corner 90°/135°



NW W20/90  
Inside  
corner 90°/135°



OPW20  
End stop  
left/right  
(set)



W20 UNIVERSAL  
Drip edge profile

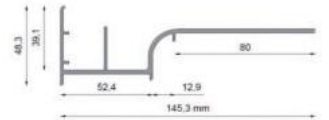

LW20  
Connector



W20Z  
Top profile



NZ W20Z/90  
Outside  
corner 90°

## W20 UNIVERSAL PROFILE - EDGING PROFILE DESIGNED TO MASK TERRACE FRONT EDGE WITH 10 MM TILE, ON RENOPAD PEDESTALS

- It allows masking of the terrace front with paving slabs, tiles, HPL panels or fibrecement slates 20 mm thick
- When used with the RENOPLAST pedestals it allows raising the floor level by 20 cm.



**INSTRUCTIONAL  
VIDEO  
W20**

1. COMPOSITE DECKING/  
TIMBER FLOORING;
2. WATERPROOFING  
(E.G.. EPDM MEMBRANE);
3. **RENOPAD PEDESTAL;**
4. **W20 DRIP EDGE PROFILE;**
5. **W20Z TOP PROFILE;**
6. 20 MM THICK TILE;
7. CEMENT SCREED

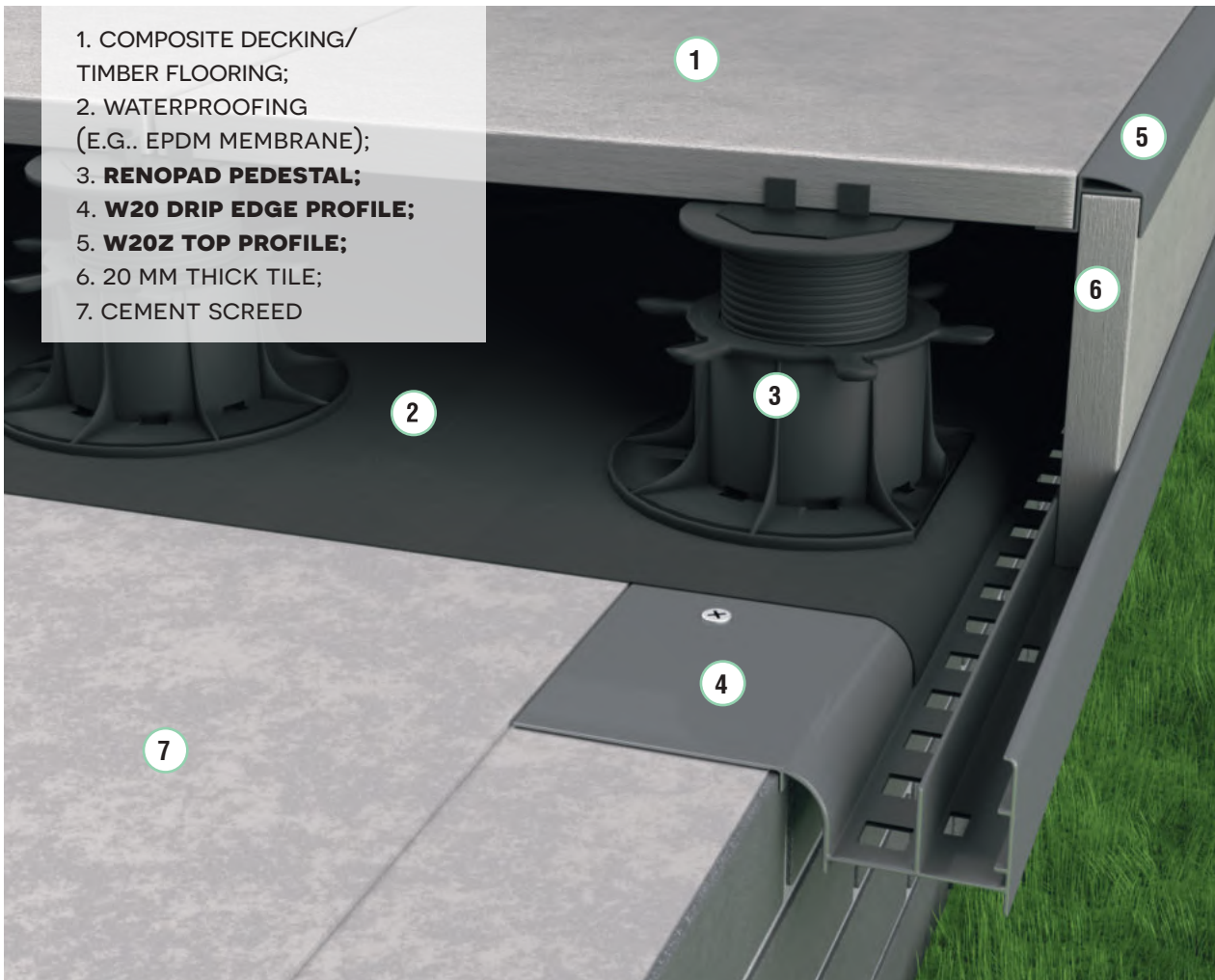

**UNIVERSAL W20 DRIP EDGE PROFILE**

# MULTI D25 DRIP EDGE PROFILE



NZ D25/90  
Outside corner 90°/135°

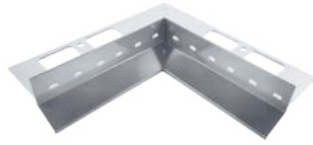

NW D25/90  
Inside corner 90°/135°



RAL 7037 RAL 7024 RAL 8019

D25 MULTI  
Drip edge profile

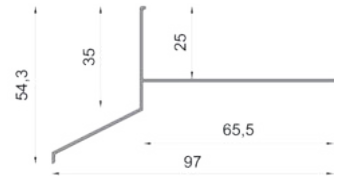

LD25  
Connector



OPD25  
End stop  
left/right  
(set)

## D25 MULTI PROFILE - PROFILE SUITABLE FOR MULTIPLE APPLICATIONS, FOR RAISED OR BONDED FLOORS

- Features peripheral drainage holes at front edge
- 25 mm high front lip of the profile
- Suitable for composite decking and timber or hick tile flooring with the use of low pedestals (8 mm).

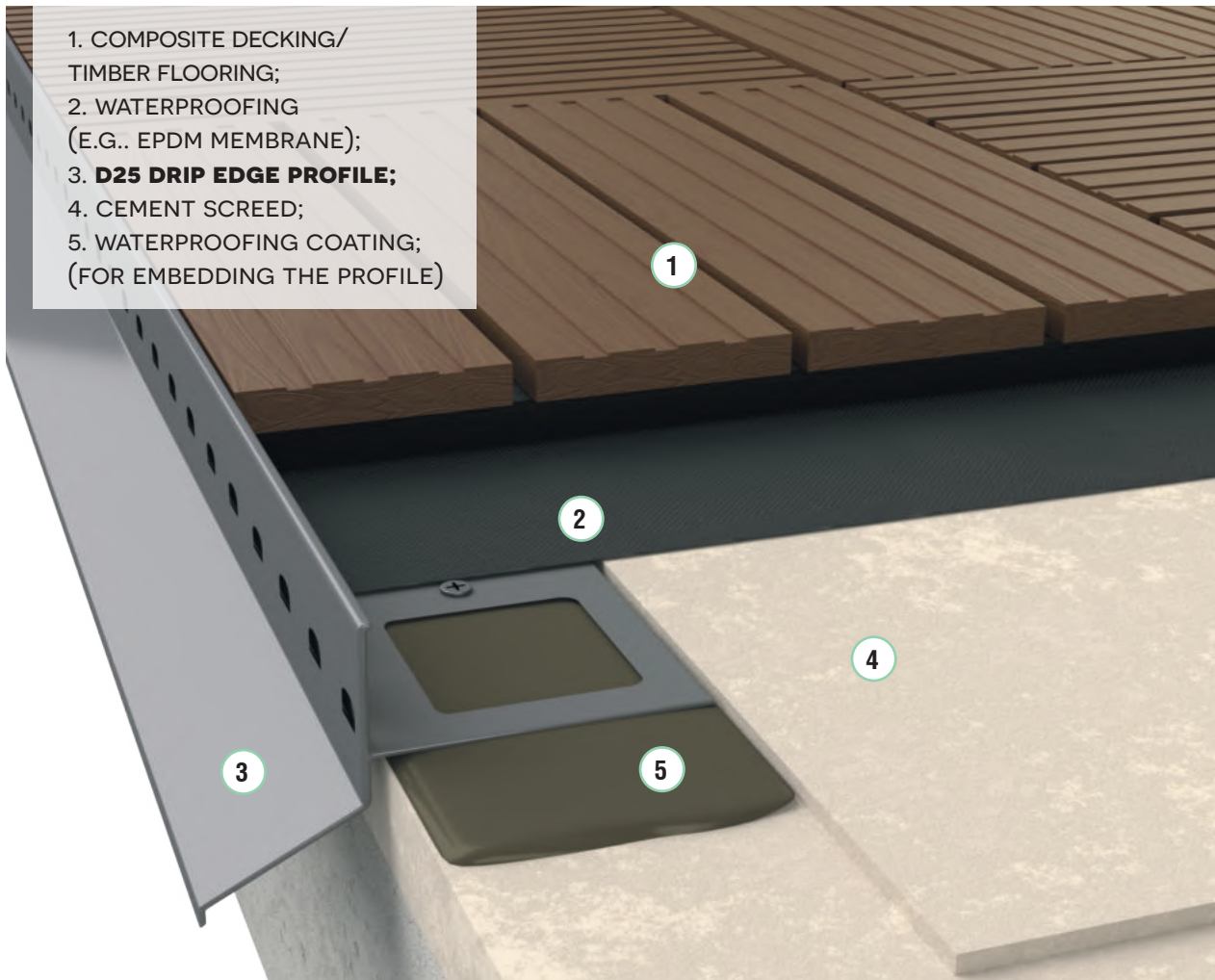

MULTI D25 DRIP EDGE PROFILE



# R50 GUTTER SYSTEM INSTALLATION

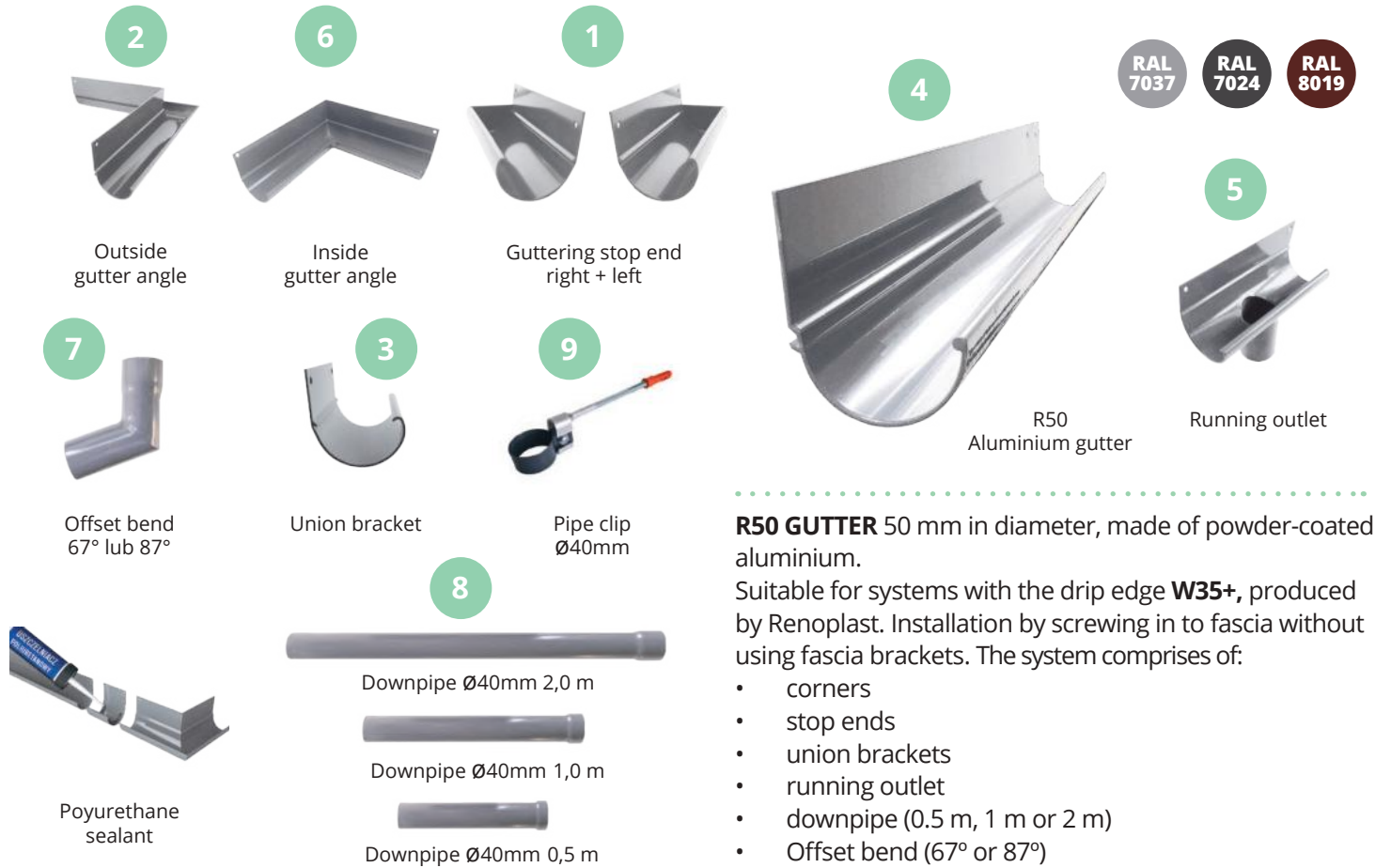

**R50 GUTTER** 50 mm in diameter, made of powder-coated aluminium.

Suitable for systems with the drip edge **W35+**, produced by Renoplast. Installation by screwing in to fascia without using fascia brackets. The system comprises of:

- corners
- stop ends
- union brackets
- running outlet
- downpipe (0.5 m, 1 m or 2 m)
- Offset bend (67° or 87°)

## GUTTER ASSEMBLY SCHEME

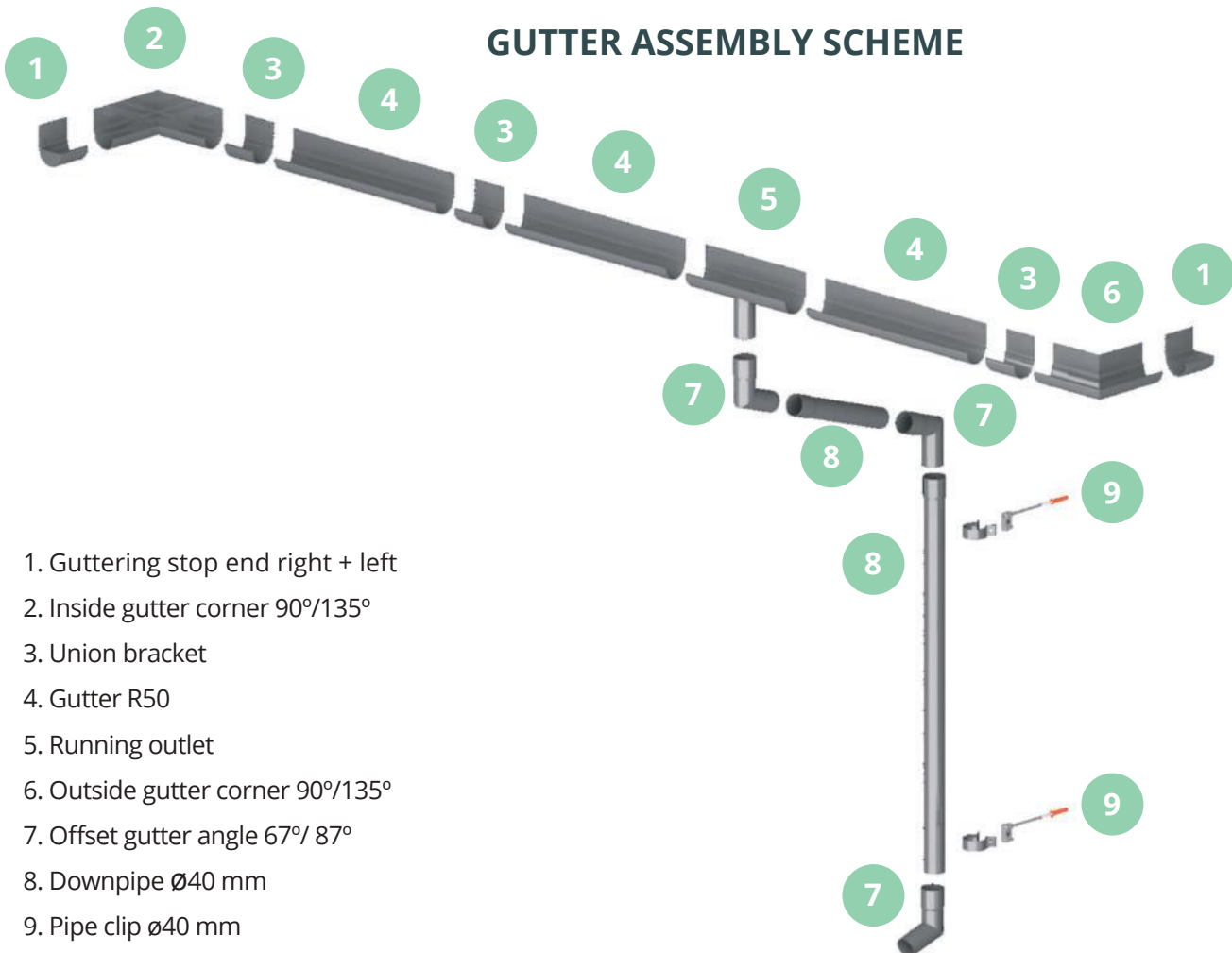

1. Guttering stop end right + left
2. Inside gutter corner 90°/135°
3. Union bracket
4. Gutter R50
5. Running outlet
6. Outside gutter corner 90°/135°
7. Offset gutter angle 67°/ 87°
8. Downpipe Ø40 mm
9. Pipe clip Ø40 mm

R50 GUTTER SYSTEM INSTALLATION

# SW STEP PROFILE

RAL 7037 RAL 7024 RAL 8019



Corner SW 90°



Top riser support



Bottom riser support



SW Step profile



SMART Support pad



Adjustment shims for SMART pads

SW PROFILE - STEP PROFILE FOR RAISED FLOOR.



INSTRUCTIONAL VIDEO SW

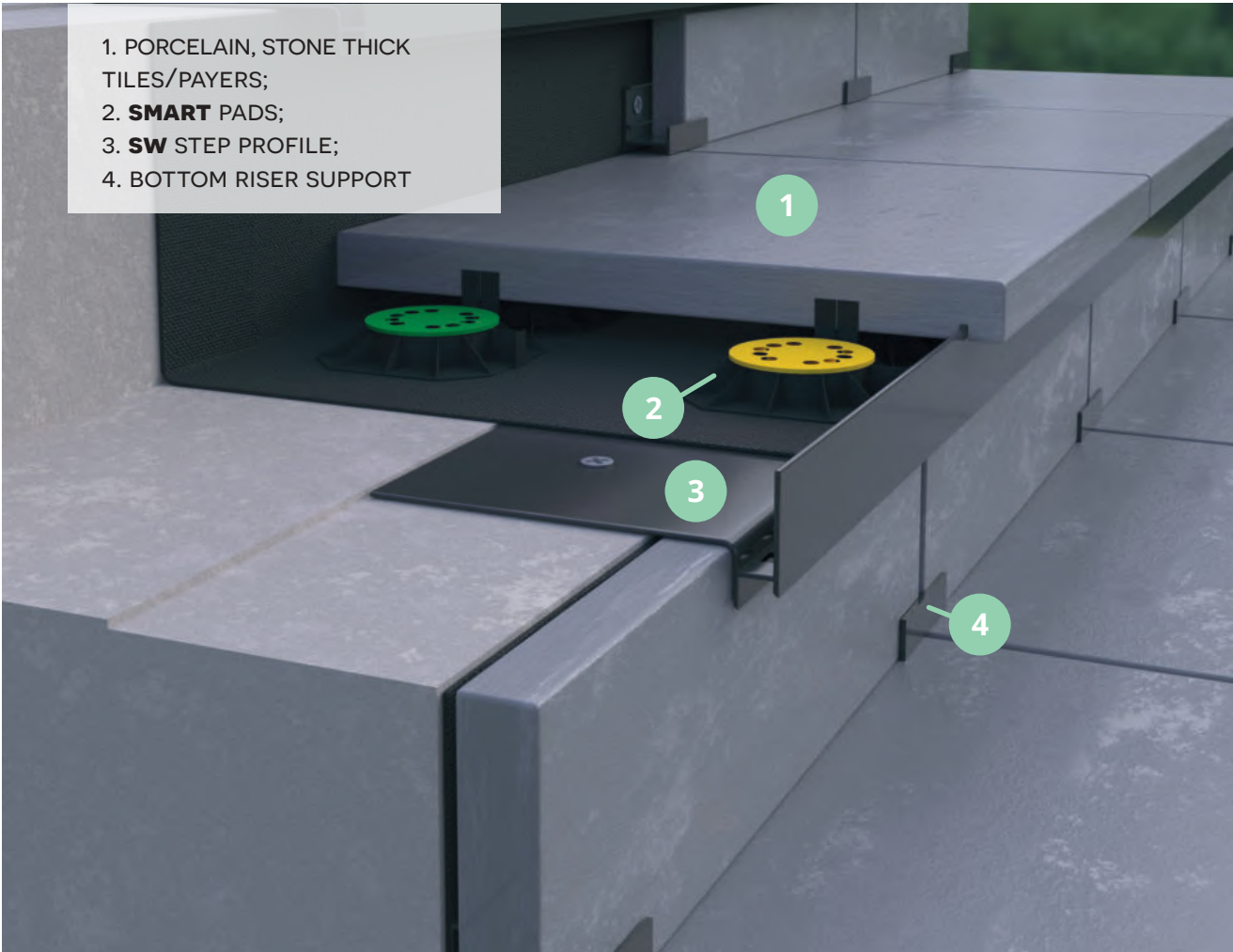
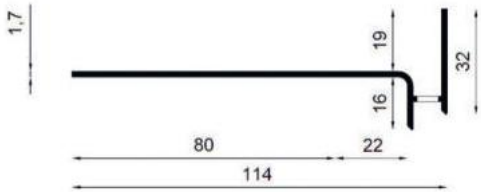

- 1. PORCELAIN, STONE THICK TILES/PAYERS;
- 2. **SMART** PADS;
- 3. **SW** STEP PROFILE;
- 4. BOTTOM RISER SUPPORT

SW STEP PROFILE



## SMART SUPPORT PADS

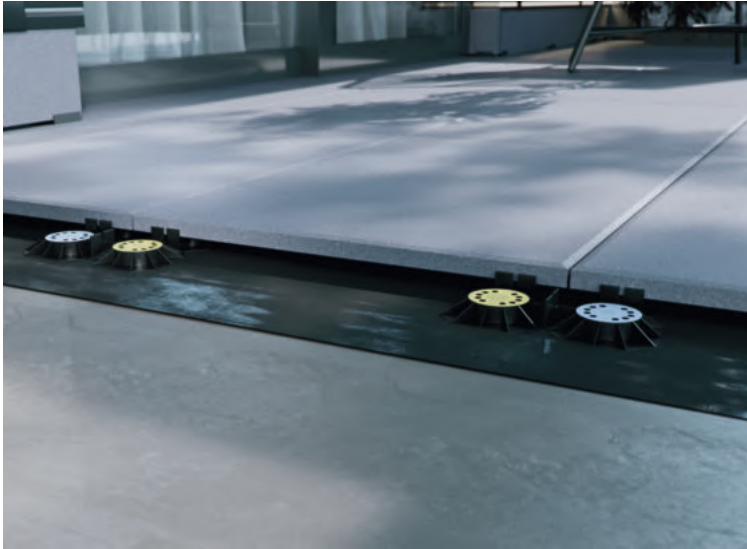

The modular design of the **SMART** pads enables point support of the paving slabs/tiles at any point. Adjustment shims of thickness 0.5 mm, 1 mm, 2 mm do 3 mm adjust and compensate for substrate unevenness and irregularity.

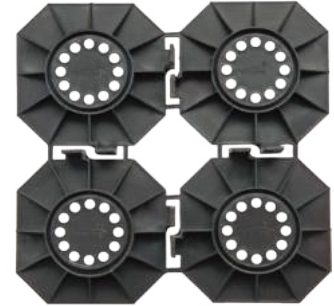

SMART pad for joint width of 2 mm or 5mm

### SUGGESTED LAYOUT OF SMART PADS

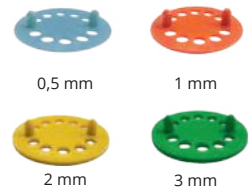
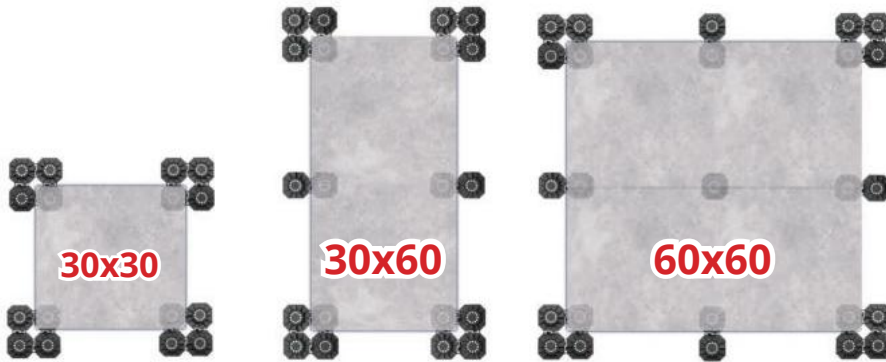

0,5 mm

1 mm

2 mm

3 mm

Adjustments shims  
0,5 mm - 3 mm  
(to compensate for unevenness)



SMART SUPPORT PADS

# RENOPAD DECKING AND PAVING PEDESTALS



Renopad decking and paving pedestals are designed for raised or ventilated floors. Replaceable heads make them suitable both for decking boards and paving slabs. Come in 7 sizes: XXS, XS, S, M, L, XL, XXL to raise the floor level between 17 and 195 mm.



Paving support  
(2 mm spacer tabs)



Joist support  
(optional)

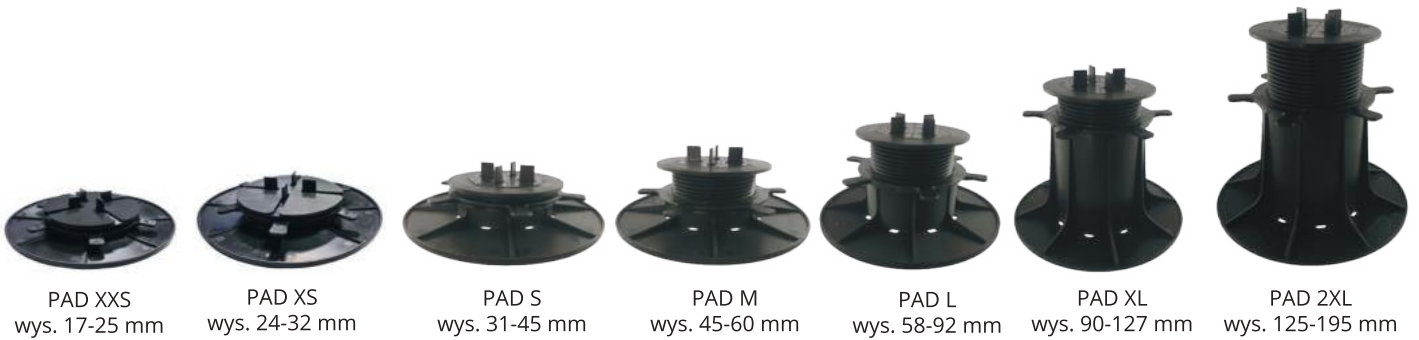

## SUGGESTED LAYOUT OF RENOPAD PEDESTALS



**60x60 CM**



**90x60 CM**



**120x60 CM**





# SKIRTING PROFILE

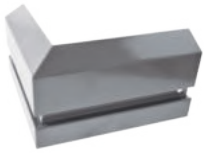

Outside corner 90° for skirting profile C2

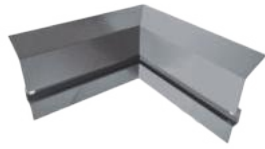

Inside corner 90° for skirting profile C2



Connector C2



Skirting end stop left/right

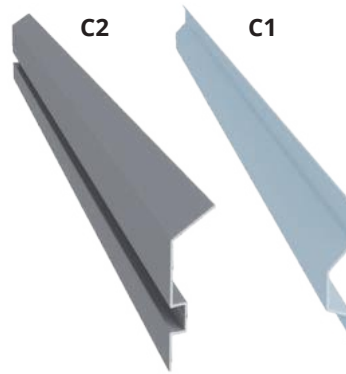

Skirting profile C1, C2

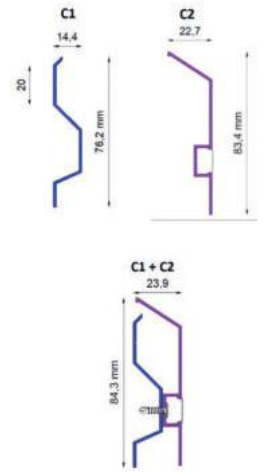

## C1, C2 SKIRTING PROFILE

- Suitable for finishing raised floor/wall interface
- Ready for assembly with LED strips
- Available accessories like connectors and end stops
- Top profile (C2) comes only in a painted version. The set also includes a cover (frosted) for the LED strip.
- Sheet support profile (C1) or bottom profile is available solely uncoated (untreated aluminium).



**INSTRUCTIONAL VIDEO**  
**C1, C2**

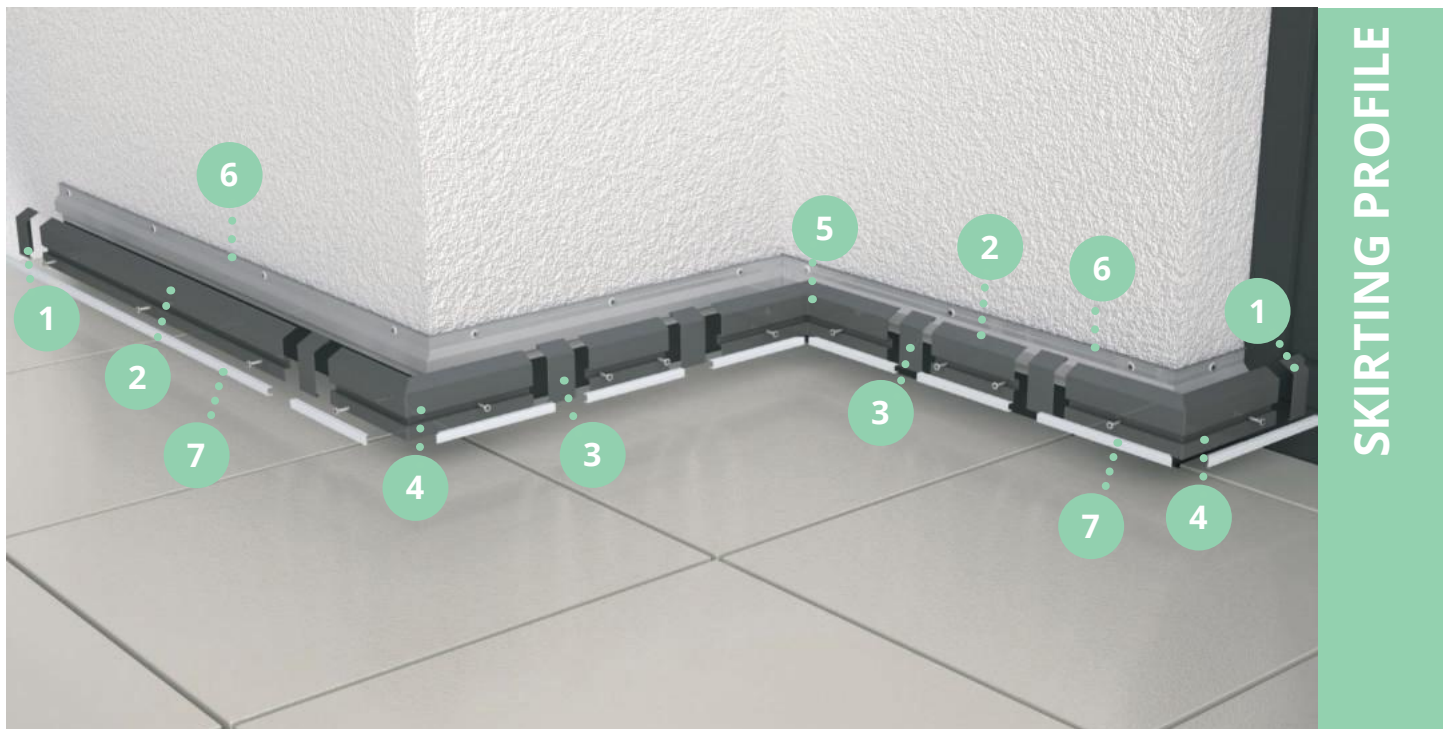

SKIRTING PROFILE



# ANCILLARY MATERIALS

RAL 7037 RAL 7024 RAL 8019



**MG75 GUTTER BRACKET**

1 set = 4 pcs brackets MG75  
+ 8 pcs screws W13  
Suitable for the Marley,  
Gamrat gutter systems

RAL 7037 RAL 7024 RAL 8019



**G75 GUTTER BRACKET**

1 set = 4 pcs brackets G75  
+ 8 pcs screws W13  
Suitable for the Bryza, Gamrat  
gutter systems



**PVC JOINT SEALING STRIP**

for W35+ profiles



**S80  
STAMP/MOULD**

2 m (80 cm wide)



**CLEVER  
WATERPROOFING STRIP**

16 cm wide  
for W35+ profiles



**JOINT SEALING  
EPDM STRIP**

for W35+ profiles

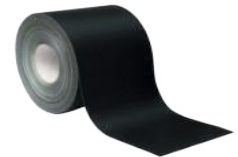

**SELF-ADHESIVE BUTYL  
SEALING TAPE**

10 cm wide

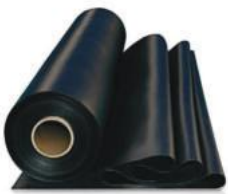

**EPDM  
MEMBRANE**

width: 1,2 m



**OUTSIDE  
EPDM  
CORNER**



**EPDM  
ADHESIVE**

0,9 kg tin



**EPDM  
SEALANT**

290 ml - cartridge  
or 600 ml



# QUICK INSTALLATION GUIDE OF RENOPLAST W30 DRIP EDGE PROFILES ON BALCONY WITH EPDM WATERPROOFING MEMBRANE AND FLORING MADE OF THICK PAVERS INSTALLED ON THE SMART SUPPORT PADS

This guide provides general guidelines and is for reference only. Application conditions (substrate and ambient humidity, application and storage temperature, setting and drying time for the products applied etc.) must be strictly observed. Please refer to the information provided in the relevant technical data sheets and packaging for more details.

1



## Balcony or terrace screed

Balcony or terrace screed should be even and sound and have a 1.5 - 2 % slope towards the front edge. It is recommended that a peripheral drop/indentation in the screed, the width corresponding to the width of the installed profile (80 mm), is formed to the depth of 3 mm to ensure that the profile is installed flush with the screed surface.

2



## Surface for baseboard waterproofing

The wall area where the membrane will be installed must be smooth and sound. It can be smoothed over with base coat and reinforced with glass fibre mesh. The wall area prepared for waterproofing should be at least 15 cm above the flooring.

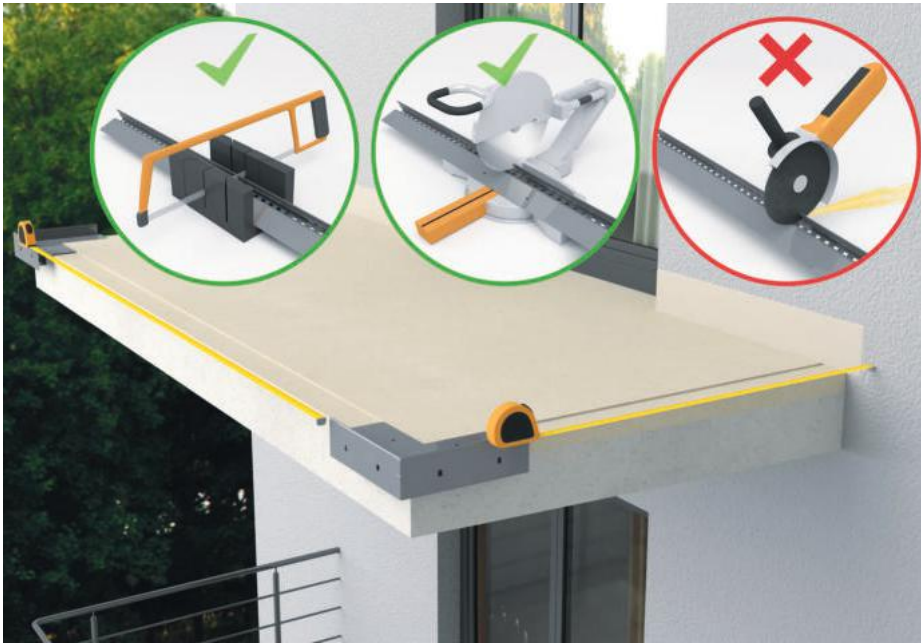

### Corners installation

Start with a mock installation of the corners. Put the corners in place to mark the locations of the anchors, drill holes, insert the anchors in the mounting holes and fix the **NZ W30/90** corners. Measure straight sections to cut the W30 profiles. Make sure that a minimum 2 mm gap is left in between the profiles at their joints as well as at the connection with the wall to allow for the end stops **OPW30**.



### Corners installation

First, install the **NZ W30/90** corners using an elastic sealing compound e.g. PU sealant and fix them to the substrate using dowels.



5



### Installation of straight profiles

Installation procedure for the **W30** straight profiles is the same as for the corners. When installed, cover the joints with the clip-on connectors **LW30**. Use builder's line stretched between the corners and a spirit level to ensure that they are aligned and flush.

6



### Installation of the EPDM membrane - preparation

Unroll the **EPDM Membrane** and lay out flat on the surface. Allow it to rest for 60 mins to make sure that transit creases and wrinkles are removed. Next, cut the membrane allowing for excess material to overlap the other sheets, extend onto the wall and on profiles.



### Bonding of EPDM membrane to the substrate

Work around the perimeter. Apply a 20 cm strip of the KS137 bonding adhesive to the substrate and the back of the sheet, to the wall area and profile surface. Both surfaces to be bonded must be coated with the bonding adhesive. Allow it to dry for 5-15 mins before you make the seam. Use a hand roller to press along the seam for good contact.



### Sealing the seams

Fold the membrane back approx. 2 cm and apply the sealant KS 96, roll the sealing area making sure that the sealant is not squeezed out. Seal at seams and joints with the drip edge profile **W30**.





### Sealing around balcony door

Use the prefabricated **EPDM outside corners** to seal the corners of the balcony reveal. Bond with the KS137 adhesive and seal with the KS 96 sealant. To seal the joint of the **EPDM membrane** with the doorstep install a **self-adhesive EPDM** tape with butyl strip.



### Laying paving slabs using SMART support pads

Lay flooring using **SMART** support pads. Layout of support pads varies with the tile/slab size. The layout for 60 x 60 cm slabs is presented above. Use adjustment shims of thickness 0.5, 1, 2 and 3 mm to adjust and compensate for substrate unevenness and irregularity. The shims are compatible with the **SMART** pads.



### Installation of C1 and C2 skirting profile

To provide secure connection of **EPDM membrane** turning up wall, install the skirting profile. First screw the **C1** support profile or base profile onto the wall.

Use a PU sealant to seal the gap running along the top edge of the **C1** profile and install the skirting tiles. Then screw in the **C2** top profile, mount corners and connectors. Finish with fitting in the plastic strip to cover the mounting channel of the **C2** profile. The **C2** profile is designed with a slot to accommodate the LED strip light that may illuminate the balcony/terrace floor.





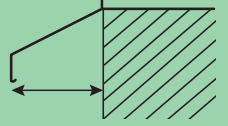

**W30 BASIC**

P. 31

2 CM  
THICK TILE

SMART



CUSTOMISED  
CURVED  
PROFILES ARE  
AVAILABLE TO  
ORDER

50 MM



**W30R BASIC+**

P. 32

2 CM  
THICK TILE

SMART

PVC 75 MM

CUSTOMISED  
CURVED  
PROFILES ARE  
AVAILABLE TO  
ORDER

70 MM  
125 MM (WITH PVC  
GUTTER)



**W35+ PRO**

P. 33

2 CM  
THICK TILE

SMART

ALUMINIUM  
GUTTER R50  
RENOPLAST

CUSTOMISED  
CURVED  
PROFILES ARE  
AVAILABLE TO  
ORDER

30 MM  
125 MM (WITH PVC  
GUTTER)



**K60 GRAND**

P. 34

2-5 CM  
THICK TILE  
OR  
DECKING  
BOARDS

SMART  
RENOPAD  
(17-195 MM)

PVC 75 MM

CUSTOMISED  
CURVED  
PROFILES ARE  
AVAILABLE TO  
ORDER

55 MM  
125 MM (WITH PVC  
GUTTER)



**W10/W20  
UNIVERSAL**

P. 35-36

2-5 CM  
THICK TILE  
OR  
DECKING  
BOARDS

RENOPAD  
(17-195 MM)



W10: 55 MM  
W20: 65 MM



**D25 MULTI**

P. 37

2-5 CM  
THICK TILE  
OR  
DECKING  
BOARDS



32 MM







# RESIN SURFACING







## PROBLEMS

**CORROSION OF  
DRIP RAIL**



**NO EFFICIENT  
WATER RUN-OFF**



**INCOMPLETE**



**LEAKING AND UNPLEASANT  
LOOKING JOINTS BETWEEN  
DRIP RAIL TRIMS**



# SOLUTION

## ANTI-CORROSION

All Renoplast profiles are coated compliant with the highest world standards which is Qualicoat-certified.

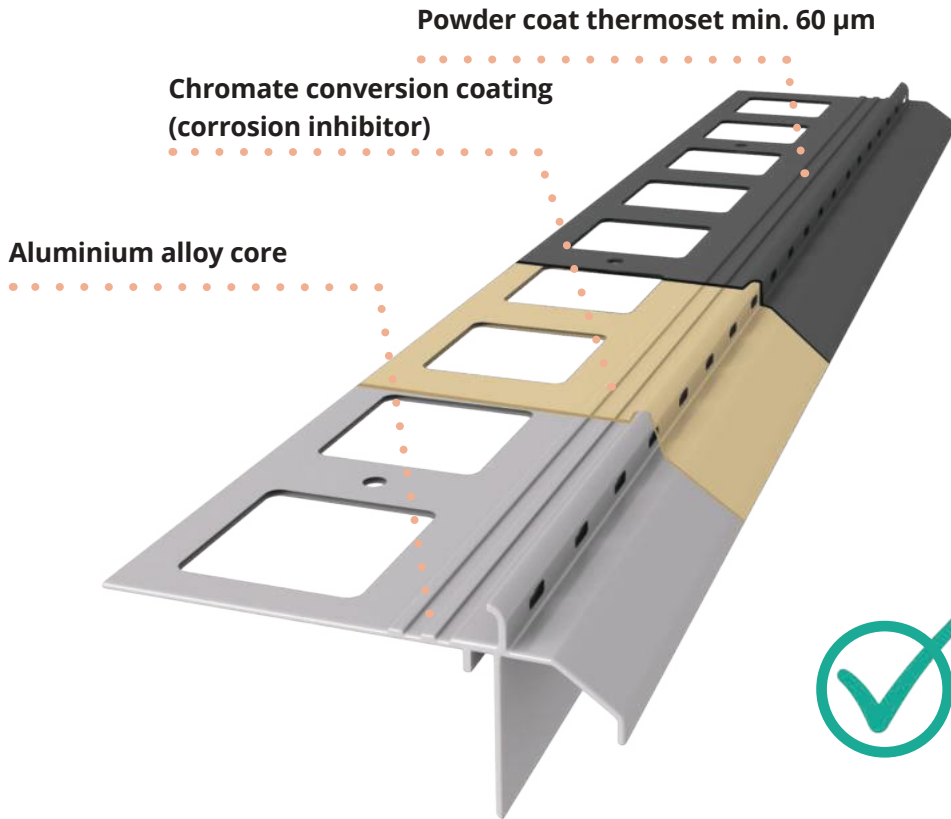

## EFFICIENT WATER RUN-OFF



A unique feature of the Renoplast profiles are drainage holes to allow a discharge of water from the surface under the tiled balcony flooring.

When the profiles are installed, the drain holes are positioned beneath allowing water to escape from the resin bound gravel.



## COMPLETE SYSTEM



We offer straight profiles (1), connectors (2), end stops (3) and outside and inside corners (4) - of standard 90° and 135° angles. Customised angle corners and curved balcony profiles are also made to order.

## WATERTIGHT JOINT BETWEEN DRIP PROFILES



Renoplast range of edging and finishing profiles provide an elegant appearance and watertight integrity to your terrace drip edge. They ensure secure and tight connection with waterproofing to efficiently drive water away from the balcony or terrace.

# BASIC K10 DRIP EDGE PROFILE



NZ 10/90  
Outside corner 90°/135°



NW 10/90  
Inside corner 90°/135°



L10  
Connector



OP10  
End stop  
left/right (set)

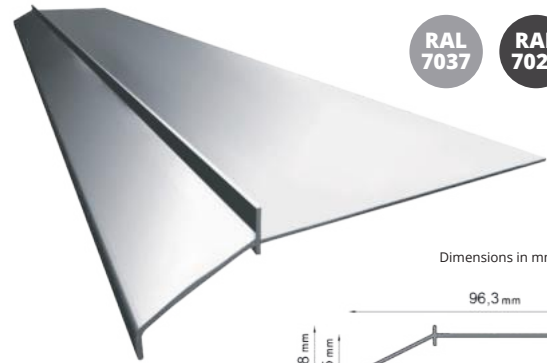

RAL 7037 RAL 7024 RAL 8019

K10 BASIC  
Drip edge profile

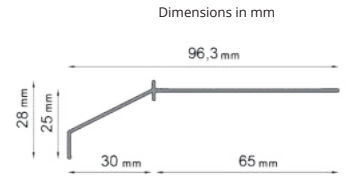

## K10 BASIC PROFILE - DRIP PROFILE FOR THIN-COAT RESIN BONDED SURFACING

### BONDED SURFACING

- Watertight connection with waterproofing and flooring
- Suitable for 2-3 mm surfacing.



**INSTRUCTIONAL VIDEO**  
**K10**

1. TOP COATING ONTO WHICH SAND IS SCATTERED WITH OR WITHOUT DECORATE FLAKES;
2. RESIN WATERPROOFING;
3. **K10 DRIP EDGE PROFILE;**
4. FLEXIBLE RESIN COMPOUND;
5. RESIN PRIMER;
6. CEMENT SCREED;

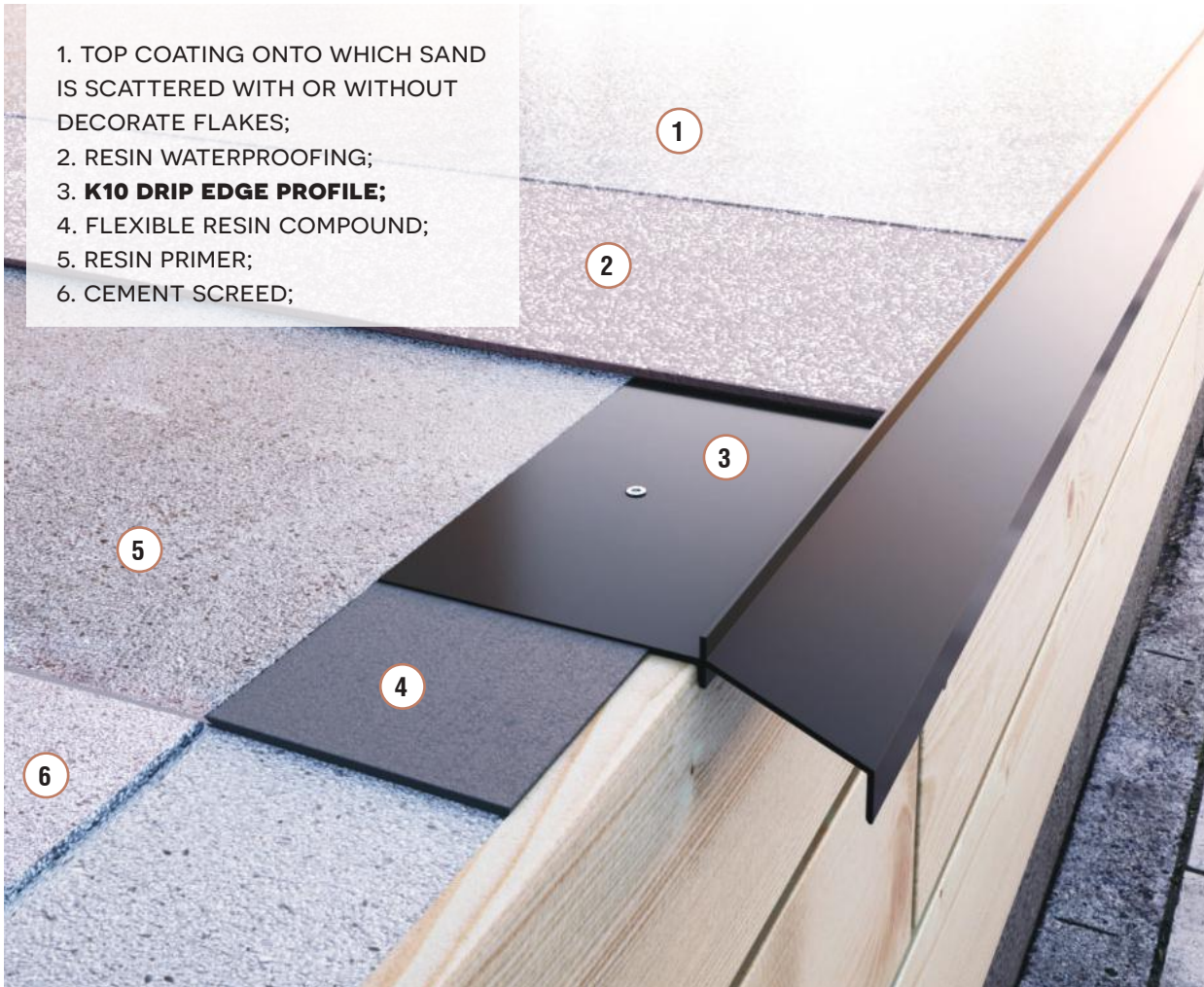

**BASIC K10 DRIP EDGE PROFILE**



# BASIC+ K10R DRIP EDGE PROFILE



NZ 10R/90  
Outside corner 90°/135°



NW 10R/90  
Inside corner 90°/135°



L10R  
Connector



OP10R  
End stop  
left/right (set)



K10R BASIC+  
Drip edge profile



R50  
Aluminium gutter

## K10R BASIC+ PROFILE - DRIP PROFILE FOR THIN-COAT RESIN BONDED SURFACING, READY FOR ALUMINIUM GUTTER R50 INSTALLATION

- Watertight connection with waterproofing and flooring
- Suitable for 2-3 mm surfacing
- Designed to allow the installation of the R50 gutters.

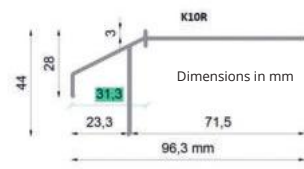

Minimal overhang of the K10R profile (without gutter) beyond balcony/terrace outer edges is: **31.3 mm or 60 mm with gutter R50.**

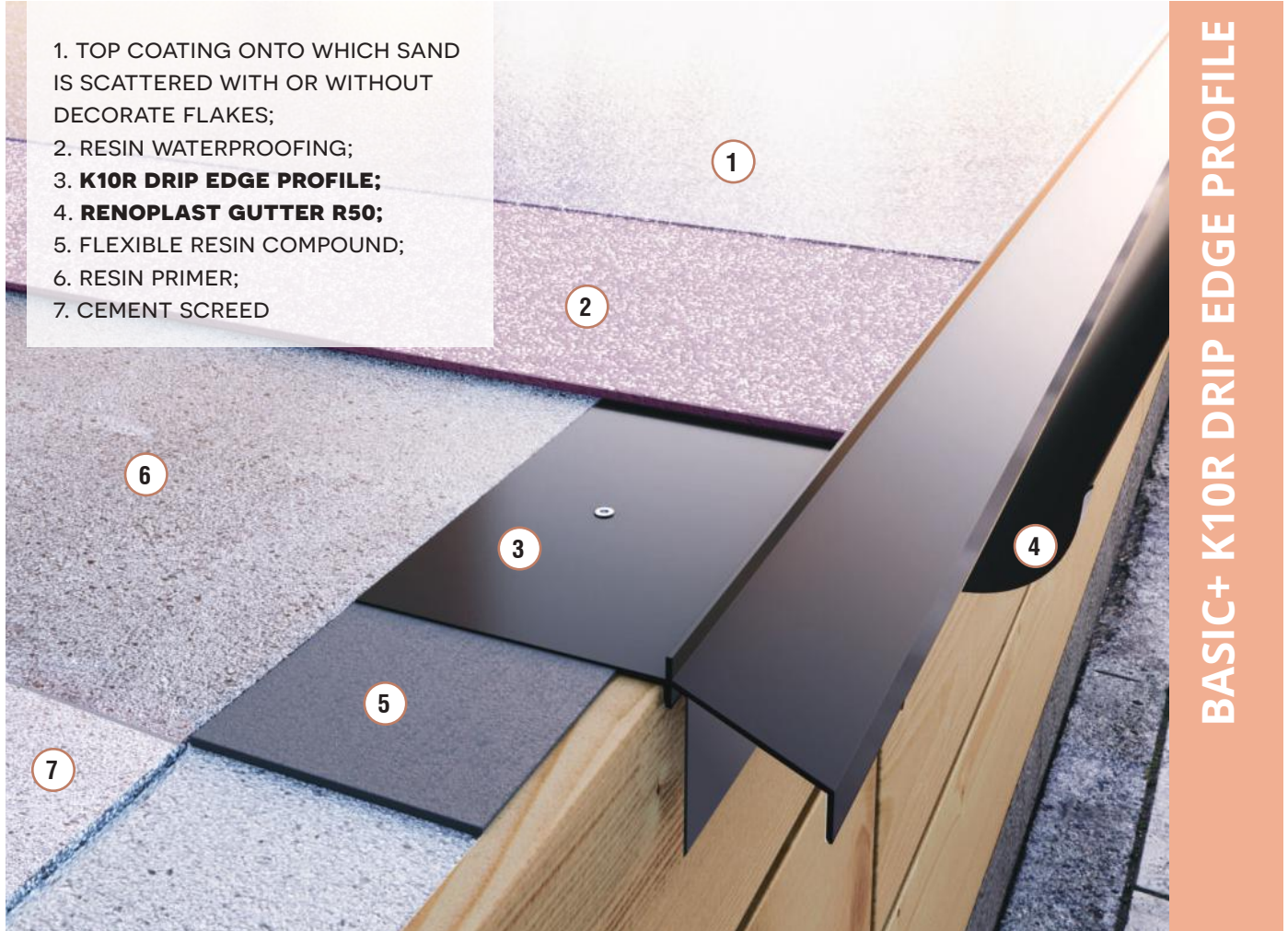

1. TOP COATING ONTO WHICH SAND IS SCATTERED WITH OR WITHOUT DECORATE FLAKES;
2. RESIN WATERPROOFING;
3. **K10R DRIP EDGE PROFILE;**
4. **RENOPLAST GUTTER R50;**
5. FLEXIBLE RESIN COMPOUND;
6. RESIN PRIMER;
7. CEMENT SCREED

**BASIC+ K10R DRIP EDGE PROFILE**

# SIMPLE K20 DRIP EDGE PROFILE



NZ 20/90  
Outside corner 90°/135°

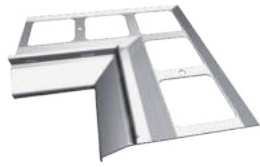

NW 20/90  
Inside corner 90°/135°



K20 SIMPLE  
Drip edge profile

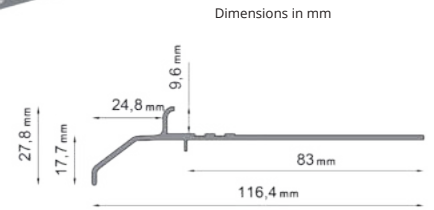

L20  
Connector



OP20  
End stop  
left/right (set)

## K20 SIMPLE PROFILE - DRIP PROFILE FOR RESIN BOUND PAVING

- Suitable for systems with waterproofing coating or epoxy waterproofing, composed of coloured aggregate bound with polyurethane resin.



1. RESIN BOUND SURFACING;
2. WATERPROOFING;
3. REINFORCING STRIP;
4. **K20 DRIP EDGE PROFILE;**
5. CEMENT SCREED;

SIMPLE K20 DRIP EDGE PROFILE



# SIMPLE+ K20R DRIP EDGE PROFILE



NZ 20R/90  
Outside corner 90°/135°

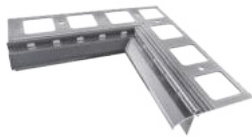

NW 20R/90  
Inside corner 90°/135°

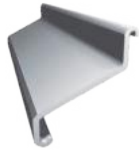

L20R  
Connector



OP20R  
End stop  
left/right (set)



R50  
Aluminium gutter



RAL  
7037

RAL  
7024

RAL  
8019

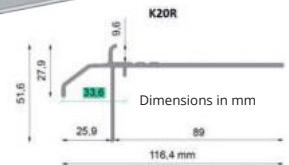

Minimal overhang of the K20R profile (without gutter) beyond balcony/terrace outer edges is: **33.6 mm** or **60 mm** with gutter R50.

K20R SIMPLE+  
Drip edge profile

## K20R SIMPLE+ PROFILE - DRIP PROFILE FOR RESIN BOUND PAVING, READY FOR ALUMINIUM GUTTER R50 INSTALLATION

- Suitable for systems with waterproofing coating or epoxy waterproofing, composed of coloured aggregate bound with polyurethane resin
- Designed to allow the installation of the R50 gutters.

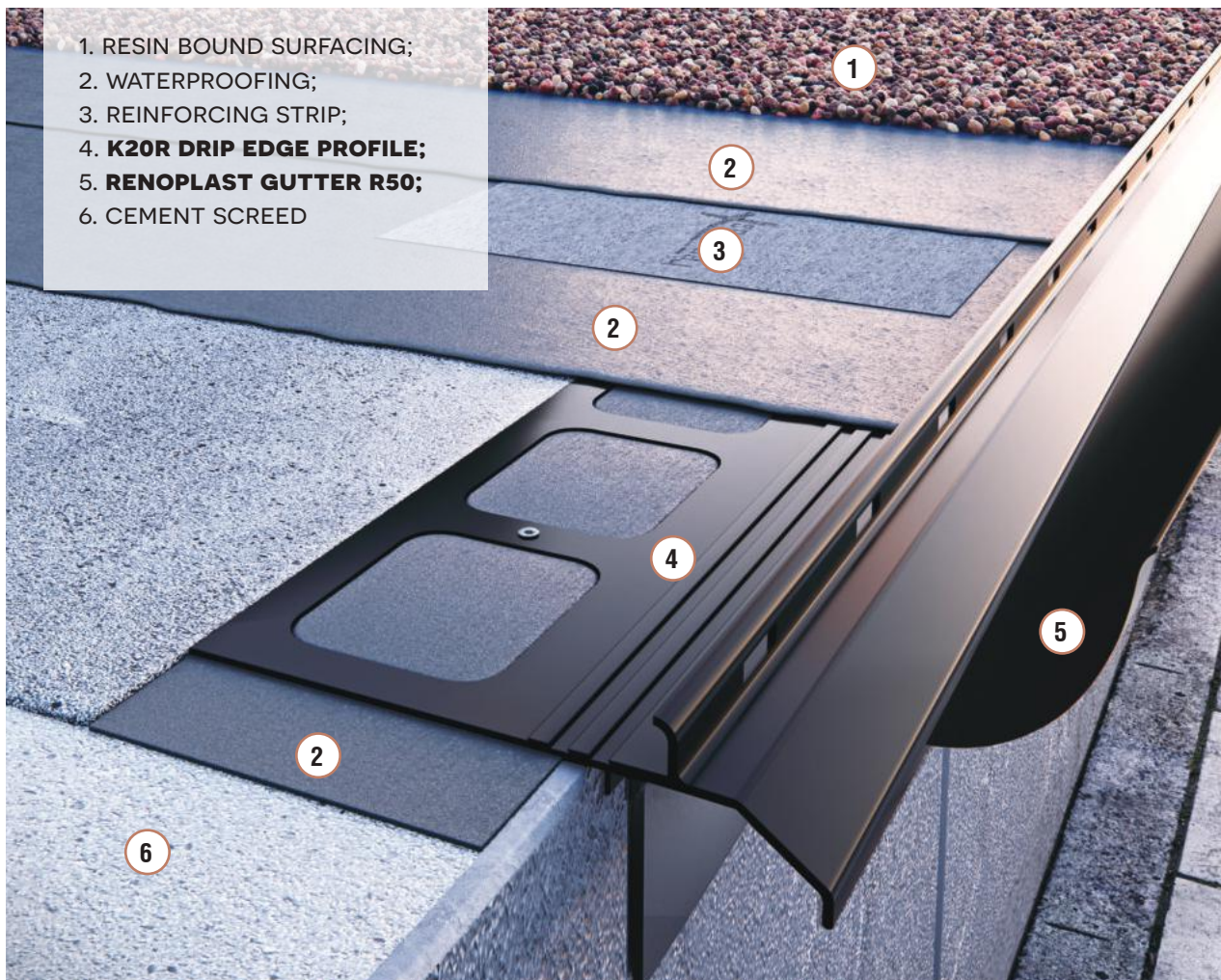

SIMPLE+ K20R DRIP EDGE PROFILE

# STEP PROFILE SZ10, SZ15, V

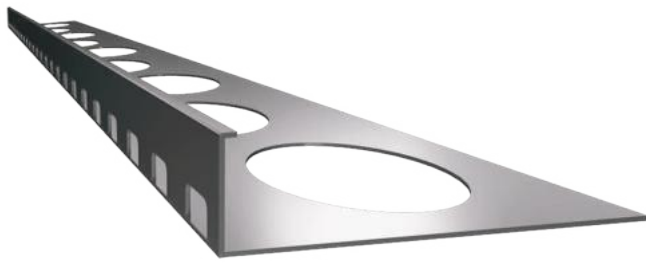

Step profile SZ10

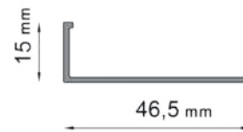

SZ15

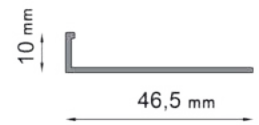

SZ10



Step profile V

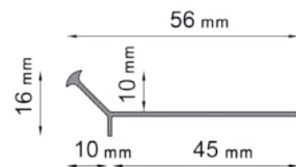

## Star nosing profiles:

**SZ10 (FINE AGGREGATE), SZ15 (COARSE AGGREGATE)**

Designed to edge and finish resin bound surfacing on floor and stairs for thickness between 10 and 15 mm

- Allow to edge between thread and riser with one profile 2m long.

## V stair nosing profile - PROFILE FOR RESIN BOUND SURFACING TO EDGE BETWEEN THREAD AND RISER

- Designed to edge resin bound surfacing on stairs
- Suitable for 10 mm thick surfacing.

1. RESIN BOUND SURFACING;
2. WATERPROOFING;
3. **V PROFILE;**
4. CEMENT SCREED

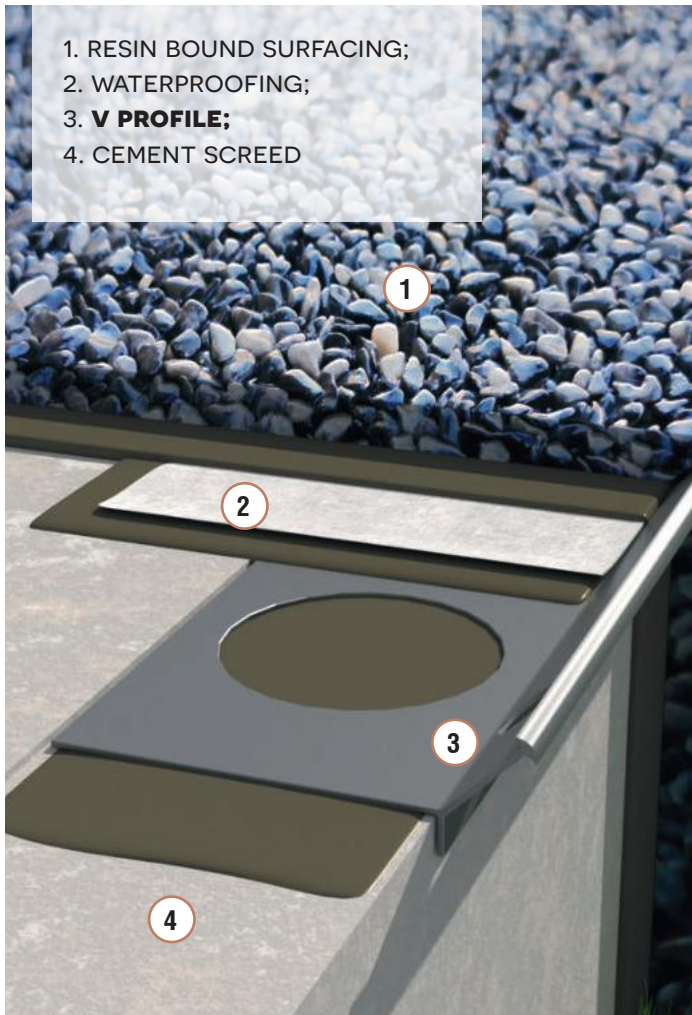

STEP PROFILE V

1. RESIN BOUND SURFACING;
2. WATERPROOFING;
3. **STAIR NOSING PROFILE SZ10/SZ15;**
4. CEMENT SCREED



STEP PROFILE SZ10, SZ15



# R50 GUTTER SYSTEM INSTALLATION

RAL 7037 RAL 7024 RAL 8019



**R50 GUTTER** 50 mm in diameter, made of powder-coated aluminium. Suitable for systems with the drip edge **K10R, K20R** produced by Renoplast. Installation by screwing in to fascia without using fascia brackets. The system comprises of:

- corners
- stop ends
- union brackets
- running outlet
- downpipe (0.5 m, 1 m or 2 m)
- offset bend (67° or 87°)

## GUTTER ASSEMBLY SCHEME

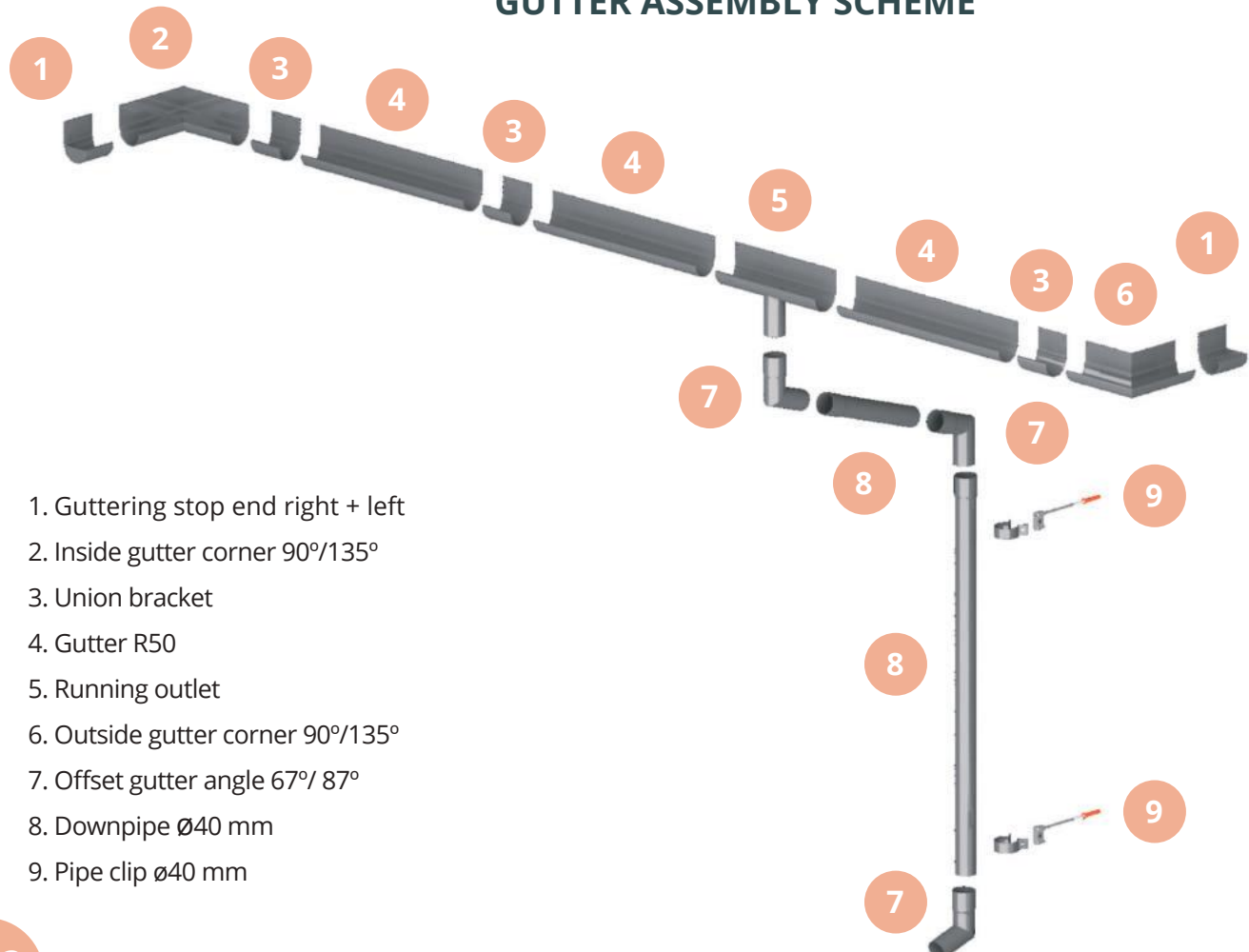

R50 GUTTER SYSTEM INSTALLATION

1. Guttering stop end right + left
2. Inside gutter corner 90°/135°
3. Union bracket
4. Gutter R50
5. Running outlet
6. Outside gutter corner 90°/135°
7. Offset gutter angle 67°/ 87°
8. Downpipe Ø40 mm
9. Pipe clip Ø40 mm

# QUICK INSTALLATION GUIDE - K10 DRIP PROFILE EDGING THIN-COAT RESIN BONDED SURFACING

This guide is for reference only. Always refer to the instructions of the resin surfacing manufacturer. Application conditions (substrate and ambient humidity, application and storage temperature, setting time of each coating, mixing ratios of resin-hardener/catalyst etc.) must be strictly observed. This guide provides general guidelines for the three-layer solution (primer, waterproofing, top coating with sand). The decision whether to embed a fibre/mesh strip in the resin only in critical areas or over the entire surface should be as per the resin manufacturer recommendations. They may vary with top coating variants.

1

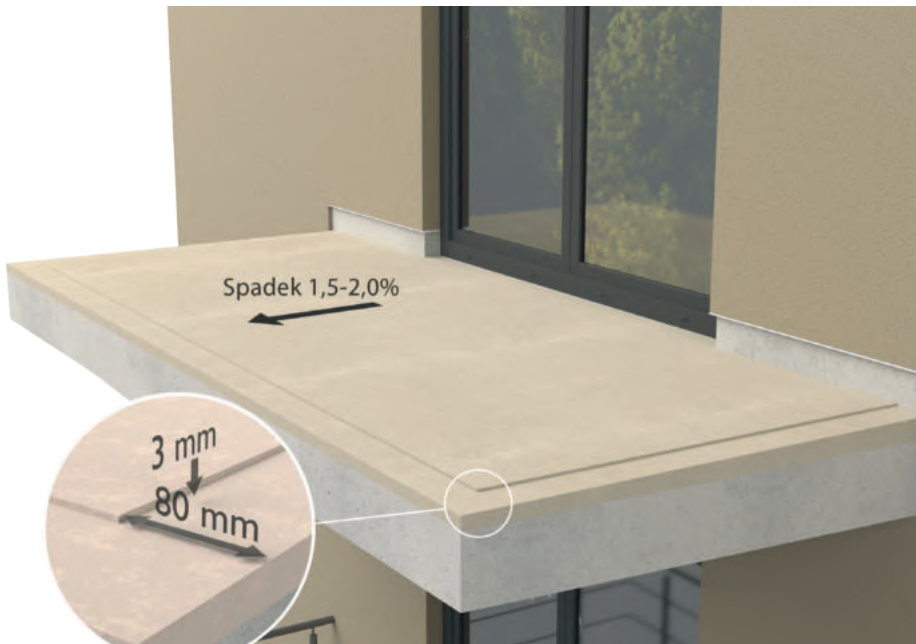

## Balcony or terrace screed

Balcony or terrace screed should be even and sound and have a 1.5 - 2 % slope towards the front edge. It is recommended that a 80 mm wide peripheral drop/indentation in the screed is formed to the depth of about 3 mm to allow for the profile to be installed flush with the screed surface.

2



## Priming

Prime the balcony or terrace screed with the concrete/cement screed primer recommended by the resin manufacturer.



3



### Initial corners installation

Start with a mock installation of the corners. Put the corners in place to mark the location of the screw anchors, drill holes, insert the anchors in the mounting holes and fix the **NZ K10/90** corners.

4



### Cutting profiles

Measure straight sections to cut the **K10** profiles. Make sure that a minimum 2 mm gap is left in between the profiles at their joints as well as at the connection with the wall to allow for the end stop **OP10/100**. Cut the profiles using a hand or power saw for cutting aluminium. Angle grinder must not be used as it can lead to local overheating and damage to the paint coating.

5

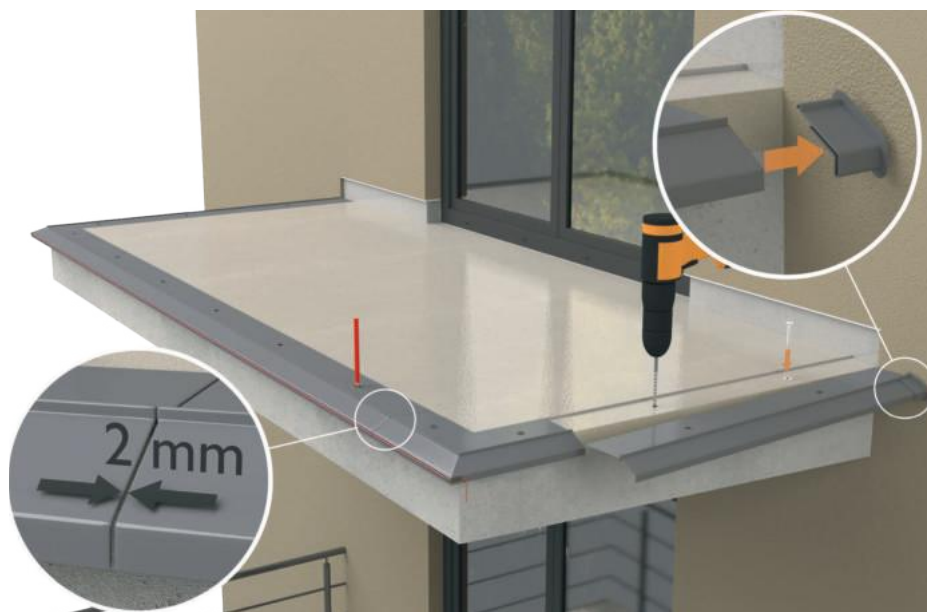

### Drilling mounting holes

Place the **Renoplast K10** straight profiles, cut to the desired length, mark drill holes, drill the holes, then remove any dust and debris and insert anchor sleeves in the mounting holes.

### Corners installation

First, embed the **NZ K10/90** corners in the resin or sealant (as instructed by the the producer) and fix them to the substrate using screw anchors.

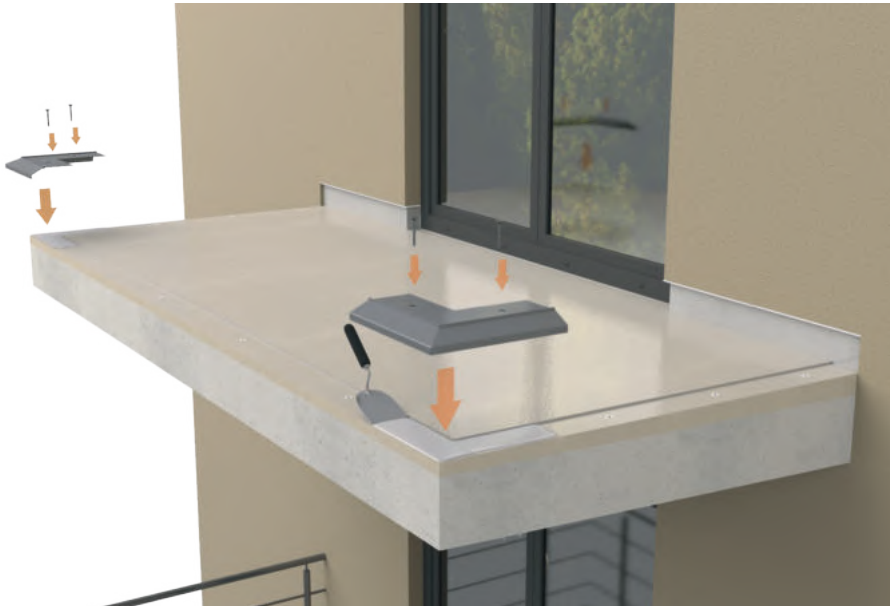

### Installation of straight profiles

Installation procedure for the **Renoplast K10** straight profiles is the same as for the corners. Use builder's line stretched between the corners and a spirit level to ensure that they are aligned and flush. Apply an elastic sealant/mastic like PU sealant to expansion joints and install the connectors **L10/100**. Pre-tighten the anchors, making sure that the sealant does not ooze out from under the profiles.



### Connection of profiles with balcony/terrace screed

When the sealant is set, tighten the anchors. Mask the outer lip of the profile with masking tape. To reinforce the connection of the anchoring leg of **Renoplast K102** with the screed and to seal it, press a fibre/mesh strip in the resin. The fibre/mesh strip should be embedded only at the joint or over entire surface as instructed by the resin manufacturer.





9

### Installation of resin waterproofing

Apply thin-coat resin and spread over the entire balcony/terrace surface to the thickness as recommended by the manufacturer.



10

### Anti-slip quartz surfacing

Before cured, scatter dry quartz on top of the resin over the entire surface.

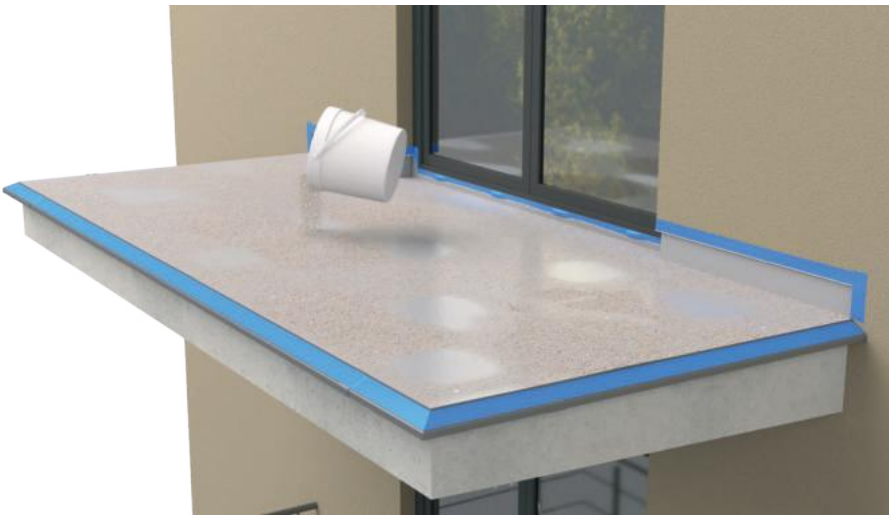

11

### Removal of excess quartz

Once the resin is cured sweep up excess aggregate.



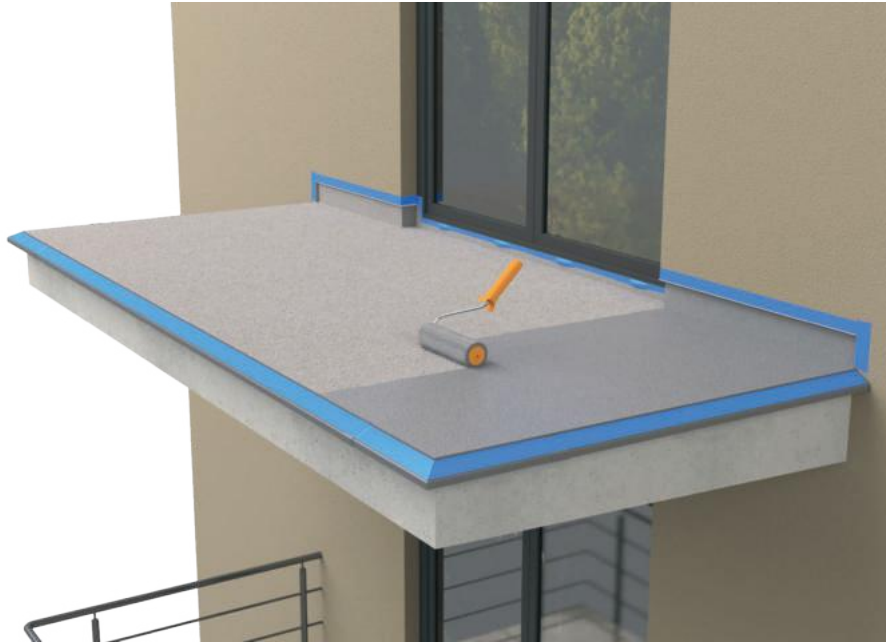

### Application of smooth surface

Spread a seal coat to the entire surface to seal, bind and protect the resin bonded surfacing and prevent the sand from getting loose from the surface. It also gives the final colour to the surface. At this stage it is possible to embed decorative colour flakes. Immediately when the work is finished, remove the masking tape.

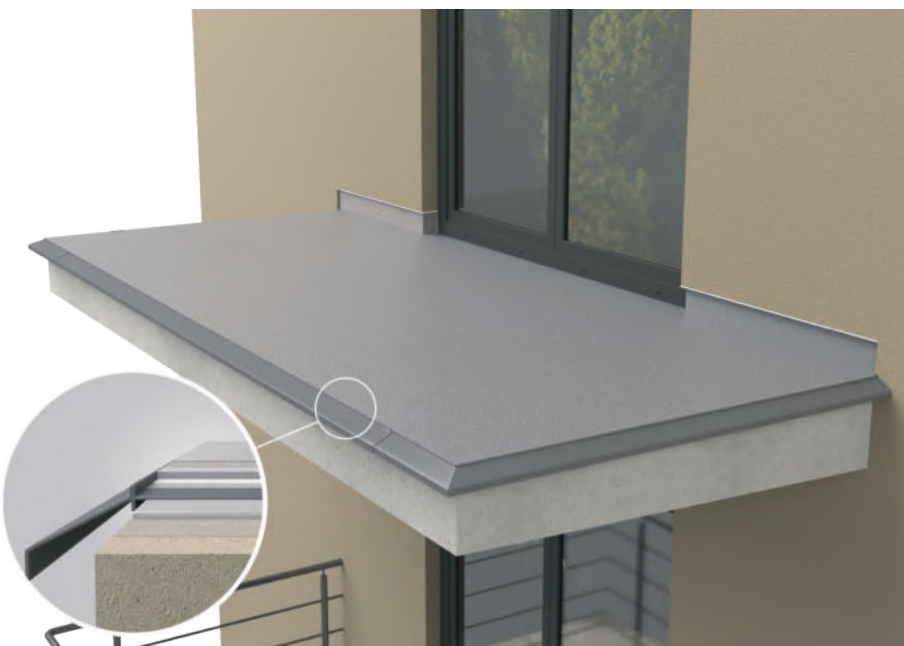

The **K10** profile front edge is 3 mm high, which makes it suitable for resin systems applied to the total thickness of 2-4 mm. This guide provides general guidelines for the three-layer solution (primer, waterproofing, sand and seal coat). The recommendations may vary with the finish variant.



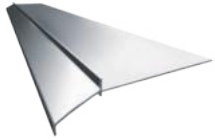
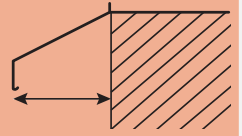
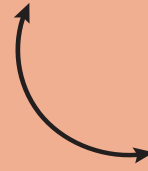

**K10 BASIC**

P. 57

THIN-COAT RESIN  
BONDED  
SURFACING

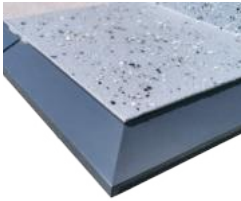

CUSTOMISED  
CURVED PROFILES  
ARE AVAILABLE TO  
ORDER

3 MM

40 MM



**K10R BASIC+**

P. 58

THIN-COAT RESIN  
BONDED  
SURFACING

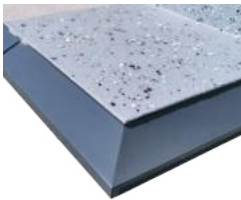

ALUMINIUM  
GUTTER R50  
RENOPLAST

CUSTOMISED  
CURVED PROFILES  
ARE AVAILABLE TO  
ORDER

3 MM

40MM  
65 MM (WITH  
GUTTER R50)

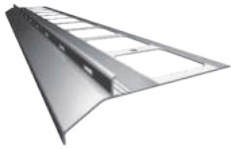

**K20 SIMPLE**

P. 59

RESIN BOUND  
FLOORING



CUSTOMISED  
CURVED PROFILES  
ARE AVAILABLE TO  
ORDER

10 MM

40 MM



**K20R SIMPLE+**

P. 60

RESIN BOUND  
FLOORING



ALUMINIUM  
GUTTER R50  
RENOPLAST

CUSTOMISED  
CURVED PROFILES  
ARE AVAILABLE TO  
ORDER

10 MM

40 MM  
65 MM (WITH  
GUTTER R50)



FAQ



**PLEASE CONTACT RENOPLAST FOR  
TECHNICAL SUPPORT ON:**

**PRZEMYSŁAW SIERADZKI  
723 870 509**

**PIOTR KUBICA  
605 932 539**

**PRZEMYSŁAW ŁUCZEJKO  
663 750 388**

**OR ON THE WEB PAGES:**

**[www.renoplast.pl](http://www.renoplast.pl)**

**[www.strefaprofesjonalisty.eu](http://www.strefaprofesjonalisty.eu)**

**<http://sklep.renoplast.pl>**

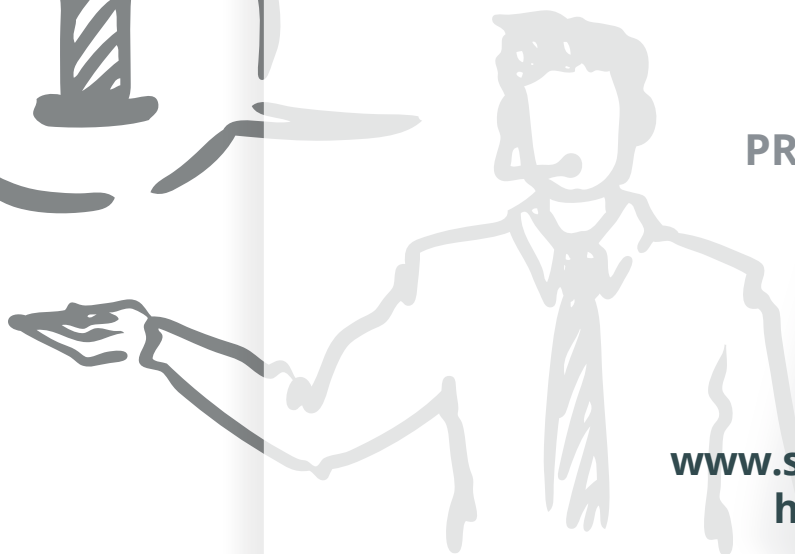

**FIND US AND LIKE ON**



Project co-financed by the European Union from the European Regional Development Fund within the framework of the Regional Operational Programme of the Silesian Province for 2007 - 2013.



# RENOPLAST SALES REPRESENTATIVE MAP



WWW.RENOPLAST.PL

BIURO@RENOPLAST.PL  
ZAMOWIENIA@RENOPLAST.PL



33 - 863 - 78 - 89

